



User Guide

SM-SERCOS

Solutions Module for:

- Unidrive SP
- Digitax ST

Part Number: 0471-0048-06
Issue: 6



www.controltechniques.com

General Information

The manufacturer accepts no liability for any consequences resulting from inappropriate, negligent or incorrect installation or adjustment of the optional parameters of the equipment or from mismatching the variable speed drive with the motor.

The contents of this guide are believed to be correct at the time of printing. In the interests of commitment to a policy of continuous development and improvement, the manufacturer reserves the right to change the specification of the product or its performance, or the content of the guide without notice.

All rights reserved. No parts of this guide may be reproduced or transmitted in any form or by any means, electrical or mechanical including, photocopying, recording or by an information storage or retrieval system, without permission in writing from the publisher.

Environmental Statement

Control Techniques is committed to minimising the environmental impacts of its manufacturing operations and of its products throughout their life cycle. To this end, we operate an Environmental Management System (EMS) which is certified to the International Standard ISO 14001. Further information on the EMS, our Environment Policy and other relevant information is available on request, or can be found at www.greendrives.com.

The electronic variable speed drives manufactured by Control Techniques have the potential to save energy and (through increased machine/process efficiency) reduce raw material consumption and scrap throughout their long working lifetime. In typical applications, these positive environmental effects far outweigh the negative impacts of product manufacture and end-of-life disposal.

Nevertheless, when the products eventually reach the end of their useful life, they can very easily be dismantled into their major component parts for efficient recycling. Many parts snap together and can be separated without the use of tools, while other parts are secured with conventional screws. Virtually all parts of the product are suitable for recycling.

Product packaging is of good quality and can be re-used. Large products are packed in wooden crates, while smaller products come in strong cardboard cartons which themselves have a high-recycled fiber content. If not re-used, these containers can be recycled. Polythene, used on the protective film and bags from wrapping product, can be recycled in the same way. Control Techniques' packaging strategy favours easily recyclable materials of low environmental impact, and regular reviews identify opportunities for improvement.

When preparing to recycle or dispose of any product or packaging, please observe local legislation and best practice.

Software Statement

This product is supplied with the latest version of software. If this product is to be used in a new or existing system with other drives, there may be some differences between their software and the software in this product. These differences may cause this product to function differently. This may also apply to drives returned from a Control Techniques Service Centre.

The software version of the drive can be checked by looking at Pr **11.29** (or Pr **0.50**) and Pr **11.34**. The software version takes the form of xx.yy.zz, where Pr **11.29** displays xx.yy and Pr **11.34** displays zz, i.e. for software version 01.01.00, Pr **11.29** would display 1.01 and Pr **11.34** would display 0.

If there is any doubt, contact a Control Techniques Drive Centre.

Copyright : © January 2009 Control Techniques Ltd

Issue Number: 6

Software : 01.03.00

Contents

1	Safety Information	6
1.1	Warnings, Cautions and Notes	6
1.2	Electrical safety - general warning	6
1.3	System design and safety of personnel	6
1.4	Environmental limits	7
1.5	Compliance with regulations	7
1.6	Motor	7
1.7	Adjusting parameters	7
2	Introduction	8
2.1	What Is SERCOS?	8
2.2	SERCOS Data transfer	9
2.3	What is SM-SERCOS?	10
2.4	Features	11
2.5	Solutions Module identification	13
2.6	Product conformance certificate	13
2.7	Conventions used in this guide	13
2.8	Backup / Auxiliary Supply	13
3	Mechanical installation	14
3.1	Solutions Module slots	14
3.2	General Installation	14
4	Electrical installation	15
4.1	SM-SERCOS terminal descriptions	15
4.2	Digital input connections	15
4.3	SERCOS connections	16
4.4	SERCOS cable	16
4.5	Maximum network length	17
4.6	Minimum cable length	17
4.7	Node addressing	17
4.8	Typical network connections	17
5	Getting started	19
5.1	SERCOS network operation	19
5.2	Using the SM-SERCOS module in Open Loop mode	21
5.3	Set-up flow chart	22
5.4	Configuring the SM-SERCOS	23
5.5	Configuring the SERCOS master	28
5.6	Control operating modes	29
6	IDNs	33
6.1	What are IDNs?	33
6.2	Supported IDNs	33
6.3	Summary of IDNs	34
7	Manufacture IDNs	71
7.1	Drive Parameter Access	71

8	Control and Status Words	73
8.1	What are control and status words?	73
8.2	MDT Control word	73
8.3	AT Status word	75
9	Procedure Commands	76
9.1	What are procedure commands?	76
9.2	Homing procedure commands	76
9.3	Displacement to the referenced system procedure command	78
9.4	Cancel reference point procedure command	78
9.5	Measurements	78
9.6	Reset class 1 diagnostic procedure command	79
9.7	CP3 and CP4 transition check procedure commands	79
10	Data Synchronisation	80
10.1	Synchronisation	80
10.2	Synchronisation status	81
10.3	Synchronisation period	81
10.4	Internal interrupts	82
10.5	Position control without interpolation	82
10.6	Position control with interpolation	83
10.7	Timing accuracy	85
11	Advanced Features	87
11.1	SM-SERCOS network loss trip	87
11.2	SM-SERCOS data endian format	87
11.3	SM-SERCOS register control	88
11.4	SM-SERCOS second encoder enable	88
11.5	SM-SERCOS second encoder source	88
11.6	SM-SERCOS second encoder turn bits	89
11.7	SM-SERCOS homing backoff behavior	89
11.8	Restore SM-SERCOS defaults	89
11.9	Storing SM-SERCOS parameters (backup)	90
11.10	Restore previous SM-SERCOS configuration	90
11.11	Marker pulse source	91
11.12	Freeze main drive position	92
11.13	Test mode	92
11.14	Disable SM-SERCOS control	92
11.15	Menu 61 - SM-SERCOS virtual parameters	93
11.16	Cyclic and non-cyclic data communications	93
11.17	Telegram type 7	94
11.18	Cyclic access to SM-Applications	94
11.19	Always require IPOSYNC bit	97
11.20	Module timer task period	97

12	Diagnostics	98
12.1	Module ID code	99
12.2	SM-SERCOS firmware version	99
12.3	SM-SERCOS node address	99
12.4	SM-SERCOS data rate	100
12.5	SM-SERCOS optical transmitter power level	100
12.6	SM-SERCOS operating status	100
12.7	Drive trip display codes	101
12.8	SM-SERCOS network diagnostic parameters	102
12.9	SM-SERCOS error codes	102
12.10	SM-SERCOS serial number	103
12.11	Diagnostic IDNs	103
13	Quick reference	104
13.1	SM-SERCOS parameter reference	104
13.2	SM-SERCOS IDN reference	106
14	Glossary Of Terms	112

1 Safety Information

1.1 Warnings, Cautions and Notes



A **Warning** contains information, which is essential for avoiding a safety hazard.



A **Caution** contains information, which is necessary for avoiding a risk of damage to the product or other equipment.

NOTE A **Note** contains information, which helps to ensure correct operation of the product.

1.2 Electrical safety - general warning

The voltages used in the drive can cause severe electrical shock and/or burns, and could be lethal. Extreme care is necessary at all times when working with or adjacent to the drive.

Specific warnings are given at the relevant places in this User Guide.

1.3 System design and safety of personnel

The drive is intended as a component for professional incorporation into complete equipment or a system. If installed incorrectly, the drive may present a safety hazard.

The drive uses high voltages and currents, carries a high level of stored electrical energy, and is used to control equipment which can cause injury.

Close attention is required to the electrical installation and the system design to avoid hazards either in normal operation or in the event of equipment malfunction. System design, installation, commissioning and maintenance must be carried out by personnel who have the necessary training and experience. They must read this safety information and this User Guide carefully.

The STOP and SECURE DISABLE functions of the drive do not isolate dangerous voltages from the output of the drive or from any external option unit. The supply must be disconnected by an approved electrical isolation device before gaining access to the electrical connections.

With the sole exception of the SECURE DISABLE / SAFE TORQUE OFF function, none of the drive functions must be used to ensure safety of personnel, i.e. they must not be used for safety-related functions.

The SECURE DISABLE or SAFE TORQUE OFF function is only available as standard on the Unidrive SP or Digitax ST. Respectively the Affinity and Commander SK drives do not have a secure disable feature.

The SECURE DISABLE function on Unidrive SP and the SAFE TORQUE OFF function on Digitax ST meet the requirements of EN954-1 category 3 for the prevention of unexpected starting of the drive. They may be used in a safety-related application. **The system designer is responsible for ensuring that the complete system is safe and designed correctly according to the relevant safety standards.**

Careful consideration must be given to the functions of the drive which might result in a hazard, either through their intended behavior or through incorrect operation due to a fault. In any application where a malfunction of the drive or its control system could lead to or allow damage, loss or injury, a risk analysis must be carried out, and where necessary, further measures taken to reduce the risk - for example, an over-speed protection device in case of failure of the speed control, or a fail-safe mechanical brake in case of loss of motor braking.

1.4 Environmental limits

Instructions in the *Unidrive SP User Guide* regarding transport, storage, installation and use of the drive must be complied with, including the specified environmental limits. Drives must not be subjected to excessive physical force.

1.5 Compliance with regulations

The installer is responsible for complying with all relevant regulations, such as national wiring regulations, accident prevention regulations and electromagnetic compatibility (EMC) regulations. Particular attention must be given to the cross-sectional areas of conductors, the selection of fuses or other protection, and protective ground (earth) connections.

The *Unidrive SP and Digitax ST User Guides* contain instructions for achieving compliance with specific EMC standards.

Within the European Union, all machinery in which this product is used must comply with the following directives:

98/37/EC: Safety of machinery.

89/336/EEC: Electromagnetic Compatibility.

1.6 Motor

Ensure the motor is installed in accordance with the manufacturer's recommendations. Ensure the motor shaft is not exposed.

Standard squirrel cage induction motors are designed for single speed operation. If it is intended to use the capability of the drive to run a motor at speeds above its designed maximum, it is strongly recommended that the manufacturer is consulted first.

Low speeds may cause the motor to overheat because the cooling fan becomes less effective. The motor should be installed with a protection thermistor. If necessary, an electric forced vent fan should be used.

The values of the motor parameters set in the drive affect the protection of the motor. The default values in the drive should not be relied upon.

It is essential that the correct value is entered in the motor rated current parameter: Pr **0.46** for Unidrive SP/Digitax ST. This affects the thermal protection of the motor.

1.7 Adjusting parameters

Some parameters have a profound effect on the operation of the drive. They must not be altered without careful consideration of the impact on the controlled system.

Measures must be taken to prevent unwanted changes due to error or tampering.

2 Introduction

2.1 What Is SERCOS?

SERCOS (**S**ERial **R**eal time **C**OMmunication **S**ystem interface) is a networking system that is intended to replace traditional wiring systems. Figure 2-1 shows the traditional cabling requirements to transfer signals between 2 slaves and a master.

Figure 2-1 Traditional cable layout

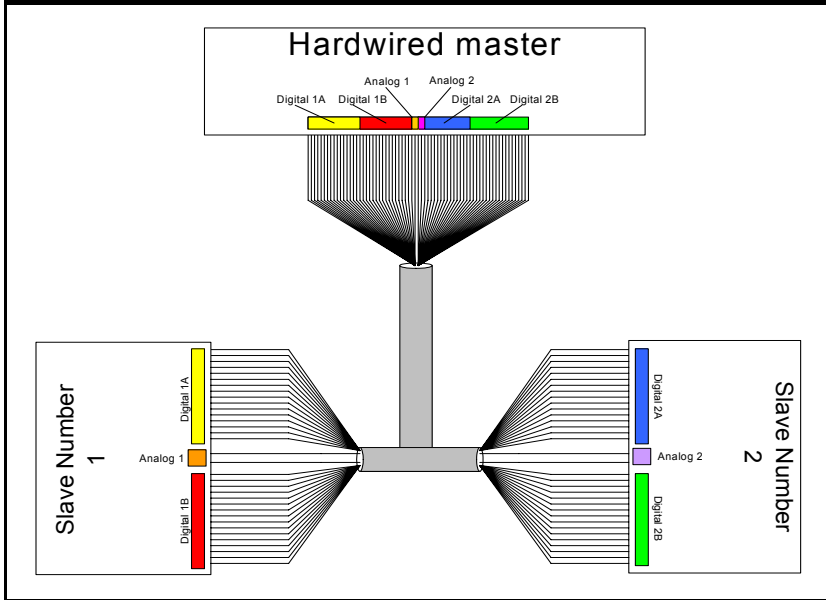
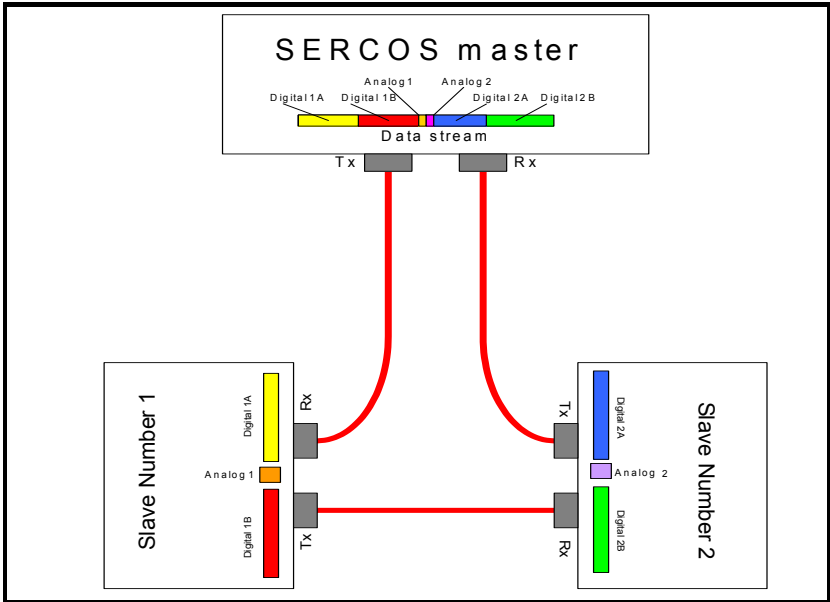

Figure 2-1 details how the wiring is used to communicate data between the master and the slaves. Each signal that is communicated requires 1 signal wire giving a total of 66 signal wires plus a 0V return.

A network system such as SERCOS allows the same configuration to be realised using only 2 optical connections per slave. This method of communication saves significantly on the amount of cabling required and can improve overall system reliability as the number of interconnections is greatly reduced.

Figure 2-2 shows a typical SERCOS network system transferring the same signals as given in the traditionally wired example. The signals are now transmitted by converting them into a optical data stream which is received by the slaves as if they were connected using traditional wiring.

Figure 2-2 SERCOS cable layout



2.2 SERCOS Data transfer

The SERCOS master reads and writes data to slaves using a pre-defined set of parameters, which provides a non-vendor specific standard for controlling slave devices. These are known as IDNs (**ID**entification **N**umbers). The SM-SERCOS interprets this data and passes it through to the appropriate drive parameters.

A SERCOS network uses three kinds of messages to handle data transfer.

- **MST - Master Synchronisation Telegram.**
This telegram is transmitted from the master on a pre-defined time basis and is used to keep the slave devices in sync with the master.
- **MDT - Master Data Telegram.**
This telegram is transmitted from the master once every network cycle. The MDT contains the cyclic data, non-cyclic data, velocity / position / torque reference and control word for each slave device.
- **AT - Amplifier Telegram.**
This telegram is the response message from a slave device and contains the slave cyclic data, non-cyclic data, velocity / position / torque feedback and status word.

It is also possible to directly access all of the Unidrive SP parameters using the manufacturer specific IDNs (see *Chapter 7 Manufacture IDNs* on page 71).

2.3 What is SM-SERCOS?

The SM-SERCOS is a Solutions Module that can be installed to any of the expansion slots on a Unidrive SP or Digitax ST to provide SERCOS slave connectivity.

By utilising the other solution module slots on the drive it is possible to have a combination of SM-SERCOS and other solution modules to add additional functionality such as extended I/O, gateway functionality, or additional PLC features.

NOTE Only one SM-SERCOS module should be installed on to a drive. If more than one SM-SERCOS module is installed only the SM-SERCOS in the lowest numerical slot will be fully functional.

Figure 2-3 SM-SERCOS

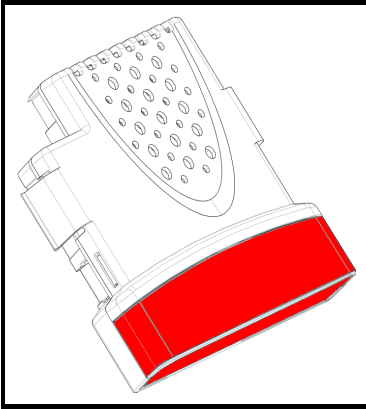

2.4 Features

2.4.1 General specification

The following section gives a brief overview of the functionality available within SM-SERCOS.

- SERCOS Class B compliant - The torque, velocity and position control modes supported.
- Supported data rates (bits/sec): 2Mb, 4Mb, 8Mb and 16Mb.
- Minimum 250µs network cycle time.
- 2 digital high-speed probe inputs for position capture.
- Telegram Type 7 Support - User definable application telegrams are supported in addition to the standard telegrams.
- Additional IDNs supported - The probing and drive controlled homing functions are included,
- Direct access to the drive parameters using the additional manufacturer-specific IDNs.
- Drive digital control loops (current, velocity, and position) are synchronised to the SERCOS master.
- Synchronous access to SM-Applications allowing specialist solutions to be implemented in SM-Applications.
- Second encoder support for one and a half axis machines (not for use with the SM-SERCOS position loop).
- Supports the Unidrive SP and Digitax ST in Servo, Closed Loop and Open Loop modes.

2.4.2 Torque control

The SM-SERCOS module provides the class B compliant torque control mode of operation. The module defines torque values as a percentage of rated torque. The torque control mode uses the torque/current control loops onboard the drive.

Users can set the torque reference, read the torque feedback and set a bipolar torque limit. They can also set a torque reference offset (referred to as the additive torque command value in SERCOS), and the current loop controller proportional gain.

2.4.3 Velocity control

The SM-SERCOS module provides the class B compliant velocity control mode of operation. The velocity control mode uses the velocity loop onboard the drive.

Users can set the velocity reference, read the velocity feedback, and set a bipolar velocity limit. Additionally they can set “At-speed” and “At zero speed” windows, and read a diagnostic parameter available over SERCOS to indicate when these conditions are true.

A velocity reference offset (referred to as the additive velocity command value in SERCOS) and the velocity loop controller proportional gain, can also be set.

2.4.4 Position control

The SM-SERCOS module provides the class B compliant position control mode of operation. This includes linear interpolation using SM-SERCOS between the master command values. Linear interpolation is necessary where the network or controller cycle times are greater than the drive cycle time (250µs). A position command value is sent each controller or network cycle, and interpolation is used to provide a position command for each drive cycle. It is possible to set the position reference and read the position feedback. A window can be set to detect when the drive is "At position" and the position loop controller proportional gain. The drive controlled homing procedure is provided – this uses the encoder marker pulse and/or a homing switch connected to the drive to datum the position feedback to a known position.

2.4.5 Control Techniques specific features

The manufacturer-specific IDN section is implemented to provide access to the drive parameter database allowing users a higher degree of control over the drive configuration. A facility is provided to synchronise other Control Techniques option modules to the SM-SERCOS module, such as SM-Applications and SM-Applications Lite. Data can be transferred synchronously to these modules to allow advanced solutions to be implemented in DPL.

A group of parameters are provided in the configuration menu of the SM-SERCOS module to which data can be written to and read from using IDNs (can only be used non-cyclically). This allows the user to control other drive option modules over the SERCOS network. A typical example would be for the user to program the embedded Advanced Position Controller (APC) on the SM-Applications module, which would run in phase with the SERCOS network cycle, adding extra functionality to the SM-SERCOS module.

2.4.6 Default Configuration

The default configuration of the module is 16Mbps at the maximum optical power level, with an address of 1. Drive parameters are provided to change the basic network parameters, including the network address (0 to 254), the optical power level and the baud rate. These parameters also allow the continuous light and zero bit stream test modes to be selected and provide diagnostics to show the progress of the phase run-up, etc. The SERCOS master specifies all other parameters over the network.

Drive parameters are also included to specify the connection of the homing switch, the probes and other features.

NOTE Always ensure that the correct baud rate is set and that all SM-SERCOS modules have a unique network address.

2.5 Solutions Module identification

The SM-SERCOS can be identified by:

1. The label located on the underside of the Solutions Module.
2. The color coding across the front of the SM-SERCOS (red).

Figure 2-4 SM-SERCOS label

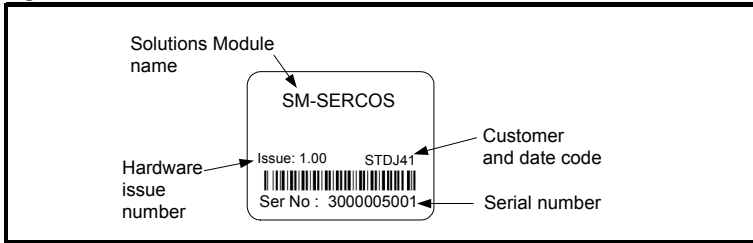

2.5.1 Date code format

The date code is split into two sections: a letter followed by a number.

The letter indicates the year, and the number indicates the week number (within the year) in which the Solutions Module was built.

The letters go in alphabetical order, starting with A in 1991 (B in 1992, C in 1993 etc.).

Example:

A date code of L35 would correspond to week 35 of year 2002.

2.6 Product conformance certificate

The SM-SERCOS has been submitted to the “Interests Group SERCOS e.V.” to be tested for full SERCOS Conformance Certification.

2.7 Conventions used in this guide

The configuration of the host drive and Solutions Module is done using menus and parameters. A menu is a logical collection of parameters that have similar functionality. In the case of a Solutions Module, the parameters will appear in menu 15, 16 or 17 for the Unidrive SP and Digitax ST depending on the slot the module is installed into. The menu is determined by the number before the decimal point.

The method used to determine the menu or parameter is as follows:

- Pr **xx.00** - signifies any menu and parameter number 00
- Pr **MM.xx** - signifies the menu allocated to the solution module. This could be 15, 16 or 17 on the Unidrive SP or Digitax ST, **xx** signifies a parameter number.

2.8 Backup / Auxiliary Supply

The Unidrive SP/Digitax ST can be connected to a back-up power supply. This keeps the control electronics and Solutions Module powered up, allowing the SM-SERCOS to continue communicating with the SERCOS master controller when the main supply to the drive is switched off. When a SM-SERCOS is installed allow for an extra 90mA of supply current to be drawn from the backup supply.

3 Mechanical installation

3.1 Solutions Module slots



Before installing or removing a Solutions Module in any drive, ensure the AC supply has been disconnected for at least 10 minutes and refer to Chapter 1 *Safety Information* on page 6. If using a DC bus supply ensure this is fully discharged before working on any drive or Solutions Module.

3.2 General Installation

The installation of a Solutions Module is illustrated in Figure 3-1.

Figure 3-1 Fitting a solutions module

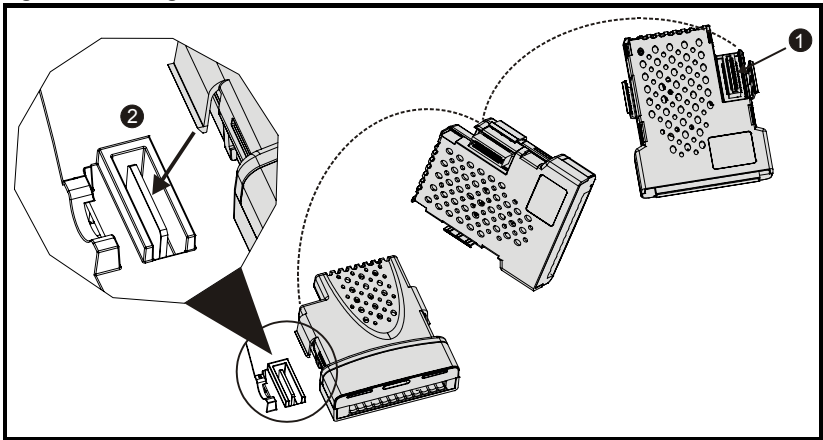

The Solutions Module connector is located on the underside of the module (1). Push this into the Solutions Module slot located on the drive until it clicks into place (2). Note that some drives require a protective tab to be removed from the Solutions Module slot. For further information, refer to the appropriate drive manual.

4 Electrical installation

4.1 SM-SERCOS terminal descriptions

The SM-SERCOS has a two connectors for the SERCOS network and a 3-way pluggable screw terminal for the module's digital inputs. The SM-SERCOS also has a diagnostic L.E.D to indicate when a network ring is not present or is severely distorted.

Figure 4-1 SM-SERCOS connectors

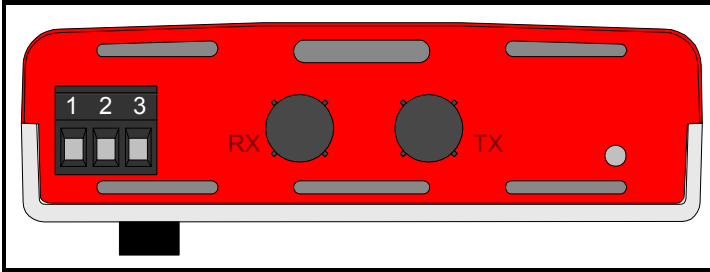

Table 4.1 SM-SERCOS connections

Terminal	Function	Description
1	0V	0V connection for digital I/O
2	DI/P0	Digital input 0
3	DI/P1	Digital input 1
RX	Rx Data	Receiver optical input
TX	Tx Data	Transmitter optical output

4.2 Digital input connections

The SM-SERCOS is equipped with 2 digital inputs for use as FREEZE, Homing and / or Marker pulse inputs.

The connector type supplied with the module is a 3.81mm pitch 3-way pluggable screw terminal labelled 1 to 3.

Table 4.2 Digital input specifications

Resolution	<1 μ s (position is calculated using linear interpolation over 250 μ s)
Logic levels	Low = 0 to +10.6V High = 11 to +24V
Absolute maximum applied voltage relative to 0V	+30V



PORT ISOLATION

The digital input circuits are isolated from the power circuits by basic insulation (single insulation) only. The installer must ensure that external control circuits are insulated from human contact by at least one layer of insulation (supplementary insulation) rated for the AC supply voltage.

4.3 SERCOS connections

The SM-SERCOS uses two 9mm F-SMA type connectors which is the standard for SERCOS. Protective screw-on dust caps are supplied installed.

The SERCOS specification states that connectors used for fiber cables must be:-

- F-SMA type.
- Quality level 5 or greater.
- Have a metallic outer ring

In addition to the specification it is also recommended that the connectors have a strain relief installed to further protect the cable.



CLASS 1 LED PRODUCT

The optical transmitter is a LED which is safe under reasonably foreseeable conditions of operation. In view of the slight possibility of the brightness being increased by a fault, users should avoid looking directly into the light.

4.4 SERCOS cable

4.4.1 Overview

SERCOS uses fiber optic cables to link between devices. Optical fibers require special care during installation to ensure reliable operation. Installation guidelines regarding minimum bend radius, tensile loads, twisting, squeezing, or pinching of cable must be followed (always refer to the cable manufacturers data sheet). Cable connectors should be protected from contamination and scratching at all times.

NOTE

Failure to adhere to these precautions may cause increased attenuation or permanent damage to the cable.

There are two types of fiber optic cables available for use with SERCOS networks:-

- Plastic fiber (polymer), often abbreviated as POF.
- Glass fiber (hard clad silica glass), often abbreviated as HCS.

The type chosen will depend upon the application. However special care must be taken when handling fiber optic cable as it is not as robust as other copper type network cables.

The SERCOS specification states that the multimode fiber optic cable used must have the following characteristics:-

- Step or graded index profile.
- Core diameter of 980 μ m plastic or 200 μ m glass.
- Cladding diameter of 1000 μ m plastic or 230 μ m glass.
- Numeric aperture of 0.47 plastic or 0.37 glass.
- Bandwidth values of $\geq 5\text{MHz} \times 1\text{km}$ or $\geq 10\text{MHz} \times 1\text{km}$.

NOTE

Control Techniques can only guarantee correct and reliable operation of the SM-SERCOS if all other equipment installed on the SERCOS network has been approved by the "Interests Group SERCOS e.V." and suitable fiber optic cable is used.

4.5 Maximum network length

4.5.1 Network loading

Due to the architecture of a fiber optic network such as SERCOS, network loading is not a limiting factor as each device on the network acts as a repeater, i.e. every incoming signal is actually buffered (re-transmitted) which means that there is never more than 2 devices connected to a section of cable.

4.5.2 Cable attenuation

Cable attenuation is an important point to consider (as with any network type) when using long length of cables. With modern optic fiber cables typical attenuation figures are approximately 220 dB/km for plastic and 6 dB/km for glass, however coupling sections of fiber optic cable together also introduces extra attenuation.

To compensate for optical fiber cable attenuation, each SERCOS device is capable of driving the optical signal at different light intensities, however it is possible to over-drive the signal which can distort it and therefore corrupt the data. Therefore the intensity selected should be chosen based on the length of each segment of fiber optic cable.

4.6 Minimum cable length

There is no minimum cable length for SERCOS, however when installing a network it is advisable to use practical and realistic cable lengths so as to avoid excessive bend radii and cable tensions.

NOTE When using very short lengths of fiber, signal distortion can be caused by excess optical transmitter power levels.

4.7 Node addressing

SM-SERCOS has an active address range of 1 to 254. Address 0 is used to disable the module from actively taking part on the network and to put it in to a passive mode where it behaves as a repeater. The addressing scheme used is at the discretion of the end user however, it is recommended that nodes are numbered in order as they appear on the physical network. It is not necessary to use consecutive numbers and gaps in the addressing scheme may be left to allow for future expansion.

In practice the maximum number of SERCOS slave devices that can be used depends upon the SERCOS cycle time and data rate. Such is the nature of these limitations that SERCOS master interfaces are often limited to only support a small number of slave devices and to be able to communicate with a larger amount of slave devices 2 or more master interface devices have to be installed into the controlling PLC or computer. While this will create multiple SERCOS networks some types of PLC or computer may ignore this and handle all SERCOS slave devices as if they were on a single network.

4.8 Typical network connections

4.8.1 Master to a single slave

Connecting a SERCOS master to a single SM-SERCOS requires the use of a duplex/zipcord or two simplex fiber cables. The SM-SERCOS default settings are such that it is ready to work on a SERCOS network in a one-to-one set-up straight away.

Figure 4-2 Connecting a master to a single SM-SERCOS Master to multiple slaves

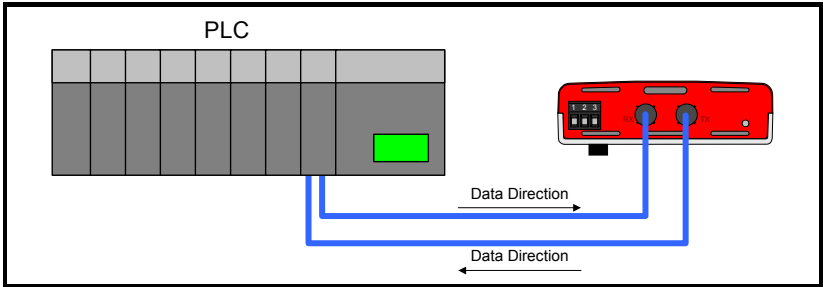

4.8.2 Master to multiple slaves

Connecting multiple SM-SERCOS modules to a master device will require the use of several lengths of simplex fiber cable.

Figure 4-3 Connecting a master to multiple SM-SERCOS modules

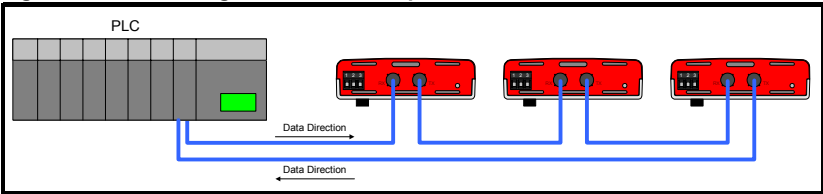

5 Getting started

This section is intended to provide a generic guide for setting up SM-SERCOS and a master controller. Figure 5-1 on page 22 is intended as a guide only and is provided to detail the stages that are required to achieve a functioning network. It is recommended that all of this chapter is read, before attempting to configure a system.

NOTE Due to the large number of masters that support SERCOS details are not provided for a specific master. Generic support is available through your supplier or local drive centre. Refer to the *Unidrive SP or Digitax ST User Guide*, for details on the drives torque and speed loop tuning (see optimisation section).

NOTE If you are contacting your supplier or local drive centre for support ensure you have read *Chapter 12 Diagnostics* on page 98 of this manual and check you have configured all parameters correctly.

Ensure the following information is available before calling:

- A list of all parameters in SM-SERCOS.
- The drive firmware version (see the relevant drive user guide).
- The system file version of SM-Applications if applicable (see the *SM-Applications User Guide*).

5.1 SERCOS network operation

5.1.1 How does it work?

A SERCOS network is based on a fiber optic ring topology, using one master to control the network, and a number of slaves (which are usually drives, and represent machine axes). SERCOS is specifically intended for motion control applications where the master is a motion controller, using a profile generator and interpolator to generate an individual motion profile for each axis. These profiles are transmitted to each axis (drive) as position commands, which are then executed simultaneously by all of the drives, it can also be used for velocity and torque control. In all of these cases, the control loops are closed within the drive and/or module. Other data about the drives, process, etc. can be transmitted over the network using non-cyclic data (the service channel).

The SERCOS master reads and writes data to a slave using a predefined set of parameters, which provides an open standard for controlling slave devices. These are known as IDNs (**ID**entification **N**umbers). The SM-SERCOS interprets this data and passes it through to the appropriate drive parameters.

NOTE To directly access the internal drive parameters over SERCOS the manufacture specific IDNs must be used. See *Chapter 7 Manufacture IDNs* on page 71.

Safety Information
Introduction
Mechanical Installation
Electrical Installation
Getting started
IDNs
Manufacture IDNs
Control and Status Words
Procedure Commands
Data Synchronisation
Advanced Features
Diagnostics
Quick reference
Glossary Of Terms
Index

5.1.2 Terminology

The state of a SERCOS device from start up (power up or re-initialisation) to full communications is known as the “Communications Phase” and consists of 5 individual phases numbered 0 to 4.

A SERCOS network uses three kinds of messages to handle data transfer.

- **MST - Master Synchronisation Telegram.**
This telegram is transmitted from the master on a predefined time basis and is used to keep the slave devices synchronised with the master.
- **MDT - Master Data Telegram.**
This telegram is transmitted from the master once every network cycle. The MDT contains the cyclic data, non-cyclic data, velocity / position / torque reference and a control word for each slave device.
- **AT - Amplifier Telegram.**
This telegram is the response message from a slave device and contains the slave cyclic data, non-cyclic data, velocity / position / torque feedback and status word.

5.1.3 Module Start-up Routine

Communications Phase 0 (CP0)

CP0 is used by the master to establish the existence of the SERCOS ring. It is not necessary for the slave devices to do anything in this phase, as long as their network repeaters are active. The master transmits MSTs and waits for them to be passed around the ring and back to the master.

Communications Phase 1 (CP1)

CP1 is entered when CP0 is completed. Each of the slaves on the ring will be interrogated by the master to establish their existence on the network. If the slave has been given address zero, it will not respond but act as a repeater. No IDNs are written to or read from during this phase.

Communications Phase 2 (CP2)

CP2 is entered when CP1 is completed. The master communicates to all the slave devices that were identified in CP1 using non-cyclic data (the service channel). The master communicates to a special group of IDNs that are used to configure the slave device for full cyclic communications. These start-up IDNs are listed in IDN 00018 and are only configurable during CP2. At the end of CP2 the master will perform a transition check (IDN 00127) to ensure that before proceeding to CP3, all of the IDNs listed in IDN 00018 have valid values. If any of the listed IDNs have failed to be set correctly, then a list of failed IDNs will be listed in IDN 00021.

Communications Phase 3 (CP3)

The drive will now synchronise its speed loop to the SM-SERCOS. While the cyclic data is now active no data is transmitted, i.e. drive operating commands such as Drive ON, Halt and Reset are ignored and the drives power stage will remain inhibited. At the end of CP3 the master will perform a transition check (IDN 00128) to ensure that before proceeding to CP4 all of the IDNs listed in IDN 00019 have valid values and the drive is properly synchronised. If any of the listed IDNs have failed to be set correctly, then a list of failed IDNs will be listed in IDN 00022.

Communications Phase 4 (CP4)

CP4 is the final phase and it is the only phase that data is exchanged cyclically. Here the drive power stage can become active (if the master selects it) and command values can be used.

NOTE Failure to perform the transition checks in CP2 and CP3 will prevent the slave advancing to the next communication phase.

5.1.4 Normal Operation

1. In full cyclic operation (CP4) the network cycle starts with the master broadcasting a Master Synchronisation Telegram (MST), which contains no data other than the network phase number. All of the slave devices are then synchronised to this message (as timings in the network cycle are measured relative to this point).
2. Each of the slaves then transmits its Amplifier Telegram (AT) to the master in a pre-defined time slot. This telegram contains feedback and status values as well as the service channel reply data.
3. The master then broadcasts the Master Data Telegram (MDT) to all of the slaves. The MDT consists of several sections, one for each slave device. Each section contains the slave's cyclic and non-cyclic data (service channel).
4. The slaves sample the necessary feedback values to be sent using the next AT and use the new command values. This is done at a pre-defined time, measured from the end of the MST.

This cycle is then repeated at regular time intervals. The period of which is set during CP2, permitted values for this time period are 250µs, 500µs and 1ms to 65ms (in 1ms increments).

NOTE All data items / network parameters are transmitted using SERCOS Identification Numbers (IDNs).

5.2 Using the SM-SERCOS module in Open Loop mode

SM-SERCOS now supports operation on the Unidrive SP and Digitax ST in Open Loop mode. If the attached drive is in open-loop mode, the torque and velocity control modes will be supported other modes will be disabled.

When in Open Loop mode and using the Velocity mode the speed reference will be written to the drive user speed reference. The position controller will be disabled in this mode.

When in Open Loop mode the user should configure the drive to use the preset reference 1 parameter (Pr 1.21) as its reference source.

Safety Information
Introduction
Mechanical Installation
Electrical Installation
Getting started
IDNs
Manufacture IDNs
Control and Status Words
Procedure
Data Synchronisation
Advanced Features
Diagnostics
Quick reference
Glossary Of Terms
Index

5.3

Set-up flow chart

Figure 5-1 Set-up flow chart

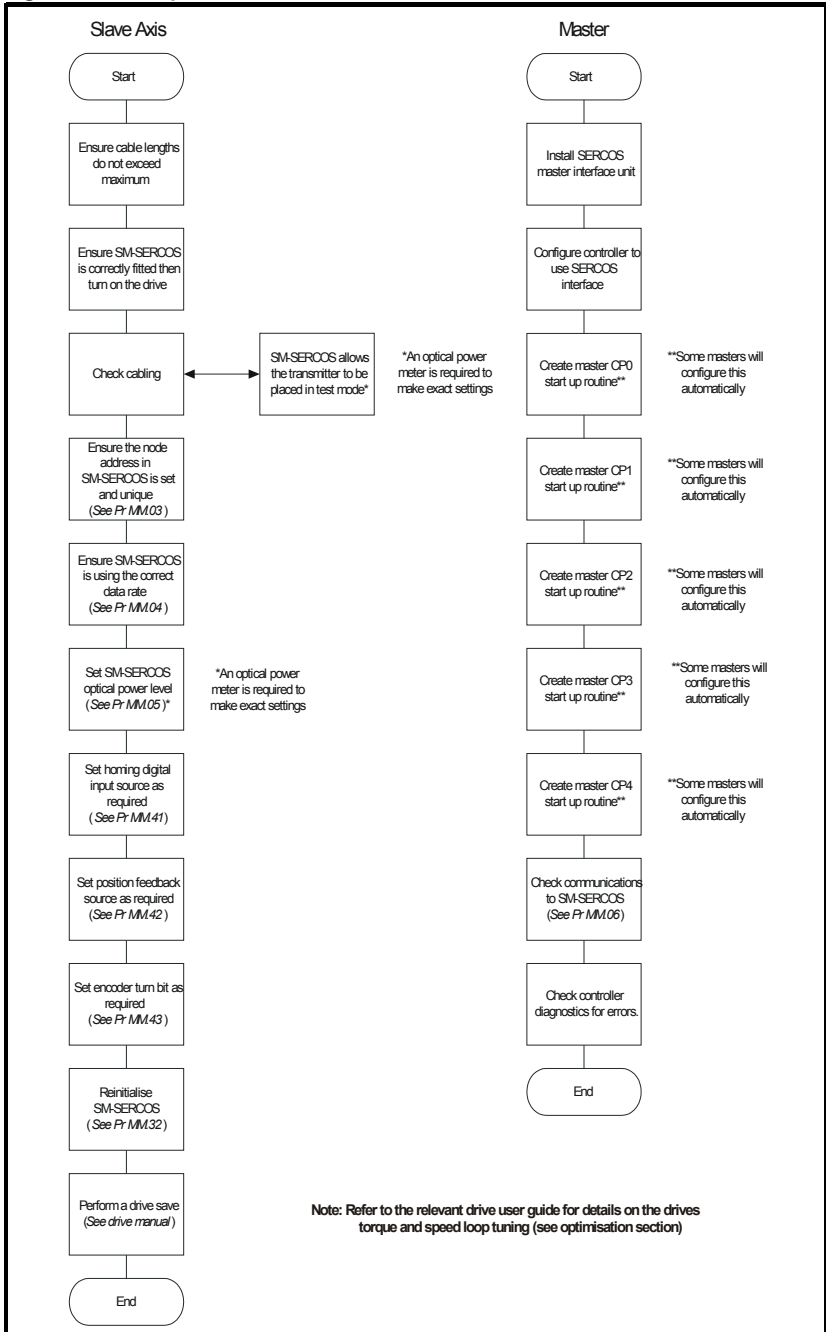

5.4 Configuring the SM-SERCOS

5.4.1 Setting the drive operating mode

SERCOS is primarily used for dynamic closed loop applications that typically employ servo drives as the slave axes. Therefore it is strongly recommended that the Unidrive SP is configured to operate in either “closed loop vector mode” or “servo mode”, prior to configuring SM-SERCOS. For details on how to change the drive operating mode see the Unidrive SP *User Guide*.

5.4.2 Setting the node address

Every node on a SERCOS network must be given a unique network node address. The SM-SERCOS node address is set using Pr **MM.03**.

SM-SERCOS node address		
Pr MM.03	Default	1
	Range	0 to 254
	Access	RW

5.4.3 Setting the data rate

All nodes (master and slaves) on the SERCOS network must be set to use the same network data rate. The SM-SERCOS data rate is set using Pr **MM.04**.

SERCOS data rate		
Pr MM.04	Default	3
	Range	0 to 3
	Access	RW

Each value represents a data rate as follows:

Table 5.1 SM-SERCOS data rates

Pr MM.04	bit/s
0	2M
1	4M
2	8M
3	16M

5.4.4 Setting the optical transmitter power level

This parameter controls the light output power level of the optical transmitter. It is provided so that different lengths and types of fiber optic cable can be used.

A value of zero means that the light is off (which effectively breaks the network ring), and four is the most intense.

SM-SERCOS transmitter optical power level		
Pr MM.05	Default	4
	Ranges	0 to 4
	Access	RW

Table 5.2 SM-SERCOS optical transmitter power levels

Pr MM.05	dBm
0	Off
1	-6.94
2	-6.38
3	-5.46
4	-5.04

NOTE These are typical values of the transmitter level and are subject to temperature variation of the installed SM-SERCOS.

To calculate a match between the fiber cable attenuation and the optical power level, the following formulae can be used to calculate the minimum and maximum transmitter power levels that can be set:-

$$P_{TXmin} = P_{RXmin} + (Att \times (l - 1))$$

$$P_{TXmax} = P_{RXmax} + (Att \times (l - 1))$$

Table 5.3 Power level formula key

Function	Description	Units
P_{TXmin}	Minimum permitted transmitter power level	dBm
P_{TXmax}	Maximum permitted transmitter power level	dBm
P_{RXmin}	Minimum permitted receiver power level -20dBm for plastic -22dBm for glass	dBm
P_{RXmax}	Maximum permitted receiver power level -5dBm for plastic -7dBm for glass	dBm
Att	Cable attenuation	dB/m
l	Length of fiber cable	m

5.4.5 Reverse on homing switch

This parameter applies to the SERCOS drive controlled homing procedure command. If this parameter is set to zero, then the procedure command will behave in the normal way. If the parameter is set to one, when the appropriate home switch edge has been detected the module will search for the marker pulse in the reverse direction. If the home switch is not to be evaluated (See description of IDN 00147), then this parameter will have no effect, and the standard homing behavior will apply.

SM-SERCOS reverse on home switch		
Pr MM.39	Default	0
	Range	0 to 1
	Access	RW

NOTE Pr MM.15 (homing backoff behavior) will alter the operation of the homing routine.

5.4.6 Homing switch digital input source

The SM-SERCOS is provided with a built-in homing routine (see section 9.2 *Homing procedure commands* on page 76). If used and depending upon the homing method required, it may be necessary to select one of the drive digital inputs as the source of the homing switch signal. When using a digital input as the homing switch input it is advisable to deselect its I/O mapping in menu 8 to avoid inadvertently setting other drive functions.

SM-SERCOS Homing switch input source		
Pr MM.41	Default	1
	Range	0 to 6
	Access	RW

A value between 0 and 6 is used to represent a digital input as follows:

Table 5.4 SM-SERCOS homing switch input source

Pr MM.41	Unidrive SP/Digitax ST digital input
0	No inputs are used
1	Digital I/O 1 - Terminal 24
2	Digital I/O 2 - Terminal 25
3	Digital I/O 3 - Terminal 26
4	Digital I/P 4 - Terminal 27
5	Digital I/P 5 - Terminal 28
6	Digital I/P 6 - Terminal 29

NOTE Pr MM.15 (homing backoff behavior) will alter the operation of the homing routine.

5.4.7 Position feedback source

If the position control mode is used it will be necessary to specify the source of the position feedback.

SM-SERCOS Position feedback source		
Pr MM.42	Default	0
	Range	0 to 3
	Access	RW

Table 5.5 SM-SERCOS position feedback source

Pr MM.42	Position feedback input source
0	Position feedback from the drive built in encoder port.
1	Position feedback from module slot 1
2	Position feedback from module slot 2
3	Position feedback from module slot 3

5.4.8 Encoder turn bits

SM-SERCOS encoder turn bits		
Pr MM.43	Default	16
	Range	1 to 16
	Access	RW

This parameter determines the resolution and scaling of the data presented to the SM-SERCOS position controller. The value determines the number of bits that the SM-SERCOS position data window is shifted by.

In a positioning system the number of positional bits made available to SERCOS through the drive and feedback system is made up from three 16-bit numbers indicating the number of whole turns, the course position and the fine position. Thus these 48 bits determine the absolute position of the motor. SM-SERCOS can only utilise 32 bits of this data and depending on the application these values will require scaling, e.g.

- A value of 16 will reduce the fine resolution of the encoder to zero, but would increase the resolution of turns to the full 16 bits.
- A value of 1 will reduce the whole turns resolution to 1 bit, but would increase the resolution of fine position to 15 bits. However, unless a suitable high resolution encoder is used then several or all of the fine bits will contain no data.

By using a suitable value in this parameter a compromise between whole turns and fine position can be achieved for a specific application. The maximum values of velocities will also be dependant on this parameter.

Figure 5-2 Encoder turn bits

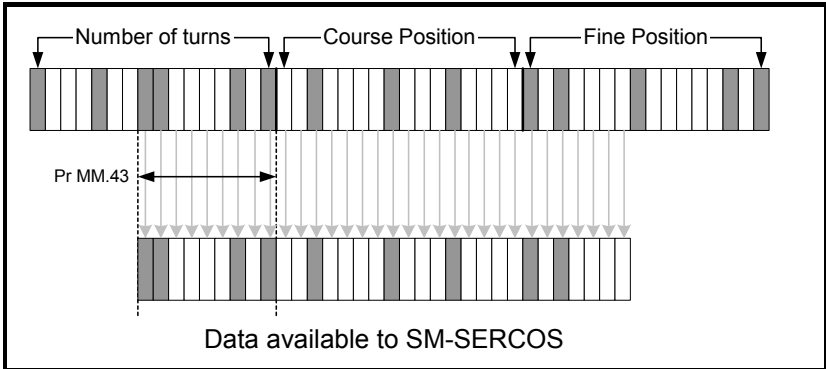

This value in this parameter will depend on the encoder type selected.

5.4.9 Re-initialising the SM-SERCOS module

Changes to the SM-SERCOS configuration in menu (15, 16 or 17) parameters will not take effect until the SM-SERCOS has been re-initialised.

To re-initialise SM-SERCOS:

1. Set Pr **MM.32** to ON.
2. When the sequence has been completed, Pr **MM.32** will be reset to OFF.
3. The SM-SERCOS will re-initialise using the updated configuration

SM-SERCOS re-initialise		
Pr MM.32	Default	0 (OFF)
	Range	0 (OFF) to 1 (ON)
	Access	RW

NOTE Pr **MM.32** will change back to OFF immediately and as such the change may not be visible on the display.

It is also possible to re-initialise all Solutions Modules* installed on a Unidrive SP/Digitax ST simultaneously by:

1. Set Pr **MM.00** to 1070.
2. Press the red RESET button on the drive.

NOTE These re-initialisation sequences do NOT store the SM-SERCOS configuration parameters in the drive or the SM-SERCOS FLASH memory.

5.4.10 SM-SERCOS operating status

This parameter provides status information about the SM-SERCOS module during and after initialisation.

SERCOS operating status		
Pr MM.06	Default	N/A
	Range	-8 to 4
	Access	RO

When the SM-SERCOS is communicating successfully with the SERCOS master controller, Pr **MM.06** will indicate the communication phase number. If there is a network or module error then Pr **MM.06** will display a negative number.

Table 5.6 SM-SERCOS operating status codes

Pr MM.06	Status	Description
4	CP 4	Communication phase 4, full cyclic operation.
3	CP 3	Communication phase 3, cyclic operation.
2	CP 2	Communication phase 2, non-cyclic operation.
1	CP 1	Communication phase 1, slave identification sequence.
0	CP 0	Communication phase 0, checking network ring presence.
-1	Network error	No network present (or is in a test mode).
-2	Initialisation failure	Module failed to initialise (or node address is zero).
-4	Module error	Error in the SM-SERCOS firmware.
-8	Re-booting	The drive interface is being initialised. This will be set for a prolonged period (up to 30s) whenever the drive database has to be re-written to the option module flash (e.g. after the drive firmware has changed).

NOTE The settings of drive parameters Pr **6.15** and Pr **3.23** should also be considered.

5.4.11 Enabling the drive control word

For a SERCOS master to be able to control a drive installed with a SM-SERCOS, the drive control word must be enabled, the SM-SERCOS can then translate the SERCOS master control word and pass it into the drive control word (Pr **6.42**).

To enable the drive control word Pr **6.43** must be set to “ON”.

5.4.12 Enabling the drive hard speed reference

For a SERCOS master to be able to control a drive installed with a SM-SERCOS, in either velocity or position control the drive hard speed reference (Pr **3.22**) must be enabled.

To enable the drive hard speed reference Pr **3.23** must be set to “ON”.

NOTE It is strongly recommend that Pr **1.14** is set to a non-analog source to avoid potential noise being introduced to the drive’s speed reference. *See the relevant drive user guide for further details.*

5.4.13 Saving parameters to the drive

To avoid loss of the configured settings when the drive is powered down save the parameter values in the drive.

To store drive parameters:

- Set Pr **MM.00** to 1000.
- Press the red RESET button.

The drive will store all parameters (except menu 20). The operation of SM-SERCOS will not be affected. Changes made to the SM-SERCOS configuration parameters will not take effect until the SM-SERCOS is re-initialised.

NOTE Menu 20 may be saved if an SM-Applications module is installed, menu 20 is stored in the SM-Applications module’s memory. See the SM-Applications documentation for more information.

NOTE If the drive is running on a backup supply only, Pr **MM.00** must be set to 1001 to perform a save. *See the Unidrive SP or Digitax ST User Guide for more details about unconditional saving of parameters.*

5.5 Configuring the SERCOS master

Due to the large amount of different SERCOS master types it is not possible to provide specific details. What follows is a generic procedure list that should be implemented when configuring a master to operate with SM-SERCOS.

NOTE Some masters will automatically configure themselves, so the following sections should be taken as a guide only. Always consult your master controller documentation.

NOTE It has been noted that certain masters do not toggle the IPOSYNC bit until after the drive has been enabled, this can lead to issues (un-requested axis movement) with SM-SERCOS system files prior to V01.02.00.

5.5.1 Communication Phase 0

1. Set the master optical transmitter power level to the required amount.
2. Set the master data / baud rate to the required value.
3. Check the status of the network ring (i.e. ensure that it is “closed”). This ensures that all the slaves are powered on and are repeating the network messages.

5.5.2 Communication Phase 1

Check that all the slave devices identified can respond correctly.

5.5.3 Communication Phase 2

1. Clear any startup errors.
2. Send timing and setup information (via the appropriate IDNs) to each slave device, this includes the slave mode of operation, i.e. Torque, Velocity or Position and other additional parameters.
3. Check that each slave passes the phase transition check.

5.5.4 Communication Phase 3

Check that each slave passes the phase transition check.

NOTE

In system file versions prior to V01.02.00 it was possible to achieve CP4 with a trip present on the drive. Versions V01.02.00 and above will not allow the SERCOS network to reach CP4 with a trip present. The only exception to this is when a UU trip is present when SM-SERCOS initialises, this will not be reported as an error, however subsequent UU trips will be correctly reported. This allows the network to be started when powering up on 24V only.

5.5.5 Communication Phase 4

This is the final stage where full operation can commence, the master now has full control of the network and slave devices.

5.6 Control operating modes

5.6.1 Overview

A drive installed with SM-SERCOS can be controlled and operated in 3 different modes.

- Torque control.
- Velocity control (including Torque feed forward if supplied).
- Position control (including Velocity feed forward if supplied).
- Position control without following error (lagless, with on board feed forward)

In each control mode, only the relevant command values can be used. For example, in the torque control mode, velocity and position command values will be ignored.

5.6.2 Torque control code

The torque control mode uses the drive current loop. The units used for the torque value are specified as a percentage of the motor rated current.

The SM-SERCOS will pass the torque reference directly to the drive current loop controller, and the value will be visible in parameter Pr **4.08** *torque reference*.

The current loop proportional and integral gains can be set from the SERCOS master over the network which the SM-SERCOS will translate and set in the drive current loop PI gain parameters (Pr **4.13**, and Pr **4.14**).

The bipolar torque limit value is handled by the SM-SERCOS module, as this function does not exist in the drive.

To be able to use the torque control mode, it is necessary for the user to set an appropriate value for the “torque mode selector” (Pr **4.11**) see *the relevant drive user guide* for details. If the operating mode is changed then Pr **4.08** will be set to zero

NOTE The SM-SERCOS position controller is disabled in torque control mode. Unless a homing routine is performed.

5.6.3 Velocity control mode

The velocity control mode uses the drive speed loop. The units used for the velocity value are in encoder counts per second.

The SM-SERCOS will pass the velocity reference and offset directly to the drive speed loop controller, and the value will be visible in Pr **3.22** hard speed reference (scaled to RPM).

The speed loop proportional, integral and differential gains can be set from the SERCOS master over the network which the SM-SERCOS will translate and set in the drive speed loop primary set of PID gain parameters (Pr **3.10**, Pr **3.11** and Pr **3.12**).

The bipolar velocity limit value is handled by the SM-SERCOS module, as this function does not exist in the drive. The velocity and standstill windows are also handled by the SM-SERCOS module as the equivalent drive functions (“At Speed” and At Zero-speed thresholds” respectively) operate at a slower update rate.

The torque reference can be written in velocity control mode (but not in position control mode). This means that the torque reference can be used as a torque feed-forward value. To be able to use the speed control with torque feed-forward, it is necessary for the user to set an appropriate value for the “torque mode selector” (Pr **4.11** = 4) see *the relevant drive user guide* for details.

To be able to use the velocity control mode, it is necessary for the user to set the “hard speed reference selector” (Pr **3.23** = ON) see *the relevant drive user guide* for details. If the operating mode is changed then Pr **3.22** will be set to zero.

NOTE The SM-SERCOS position controller is disabled in velocity control mode.

5.6.4 Position control mode

The SM-SERCOS module has an in-built position controller that is synchronised with the drive control loops (i.e. every 250µs).

As it is possible to have different network, drive and master cycle / scan times, the SM-SERCOS has a basic linear interpolator that increments the position reference in steps up to the next command value. The interpolator stores the “next” and “current” position values. When active it will move the “next” position value to the “current” value and load a new “next” position value. This means that a position value will be delayed by one controller cycle time period. When the controller and network cycle times are both the same as the drive cycle time i.e. 250µs, the interpolation is not required, however, there will be an artificial delay introduced, so that the position command will be placed into the position control loop 250µs later.

Position values (course and fine) exchanged over the SERCOS network are specified in terms of encoder revolutions, Pr **MM.43** is used to scale this (see section 5.4.8 Encoder turn bits on page 26).

The SM-SERCOS position controller outputs a velocity demand in RPM to the drive’s speed loop, the value of which can be viewed in the hard speed reference parameter Pr **3.22**.

The velocity command IDN value (IDN 00036) is used as a feed-forward value in the position controller. A position window can be defined that will set a status bit when the actual position is within a certain range of the position set-point. The difference between the position command and position feedback (the following distance) will be compared with this window value. If the following distance is smaller, the status bit will be set.

In position control without following error (lagless), the velocity feed forward is generated onboard and the velocity IDN (IDN 00036) is ignored. It is possible to set the velocity feed forward (IDN 00296) gain if it is required.

To be able to use the position control mode, it is necessary for the user to set the “hard speed reference selector” (Pr **3.23** = ON), see the *relevant drive user guide* for details. If the operating mode is changed then Pr **3.22** will be set to zero.

Safety Information
Introduction
Mechanical Installation
Electrical Installation
Getting started
IDNs
Manufacture IDNs
Control and Status Words
Procedure Commands
Data Synchronisation
Advanced Features
Diagnostics
Quick reference
Glossary Of Terms
Index

Figure 5-3 Position and velocity logic diagram

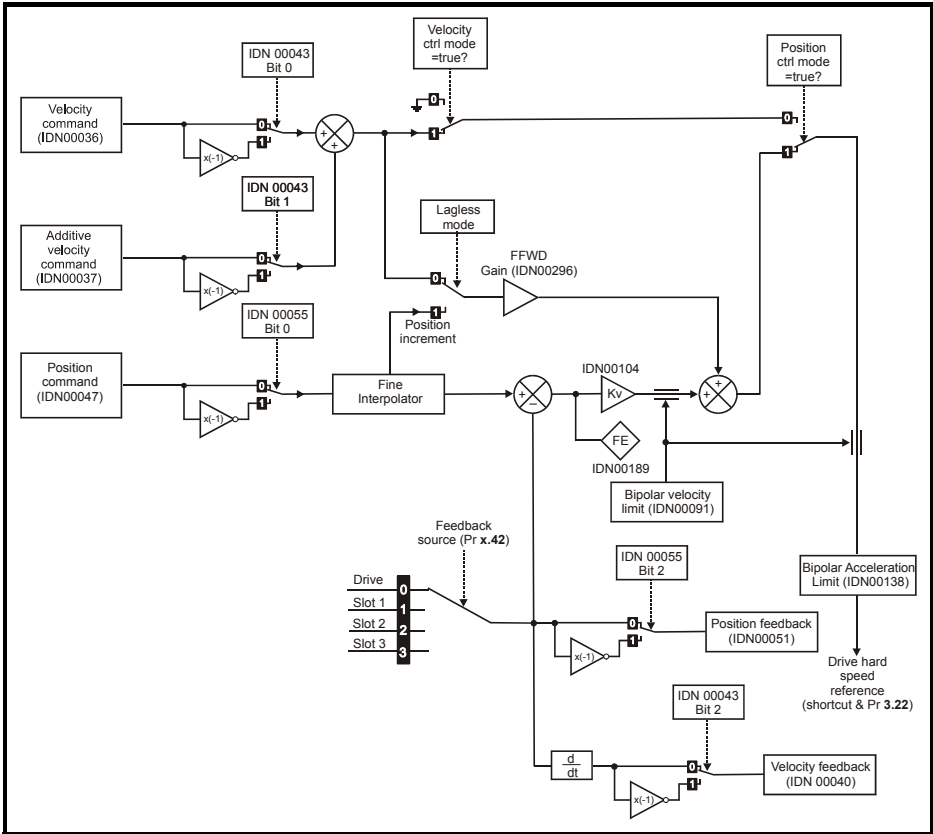
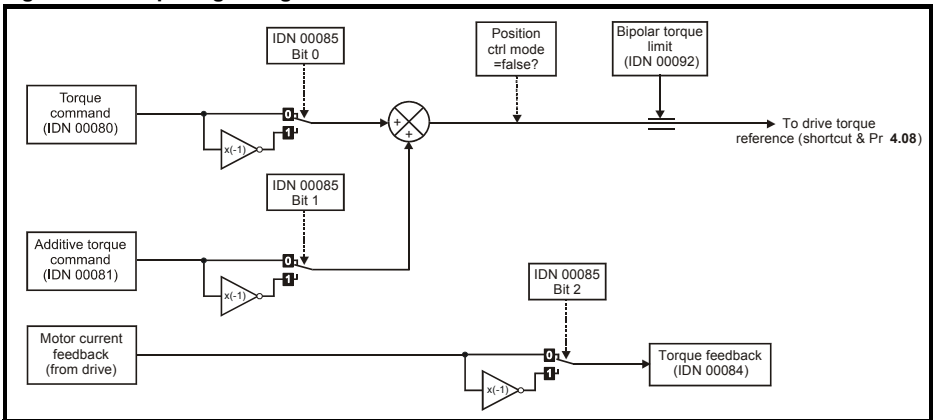

Figure 5-4 Torque logic diagram



6 IDNs

6.1 What are IDNs?

IDNs (**ID**entification **N**umbers) are a predefined list of SERCOS parameters. Several of the basic IDNs are used to set-up the network operating parameters, others are used specifically during slave configuration and the rest are used for normal data transaction handling. The additional manufacturer specific IDNs while still being defined by the SERCOS specification are used to set-up and/or control functions specific to the slave device.

Several of the basic IDNs are used to configure the timing sequences used within SERCOS.

The timing sequence within SERCOS is critical as all network operations are based upon it. Figure 6-1 shows a basic timing sequence chart for a SERCOS network.

Figure 6-1 SERCOS network timing sequence chart

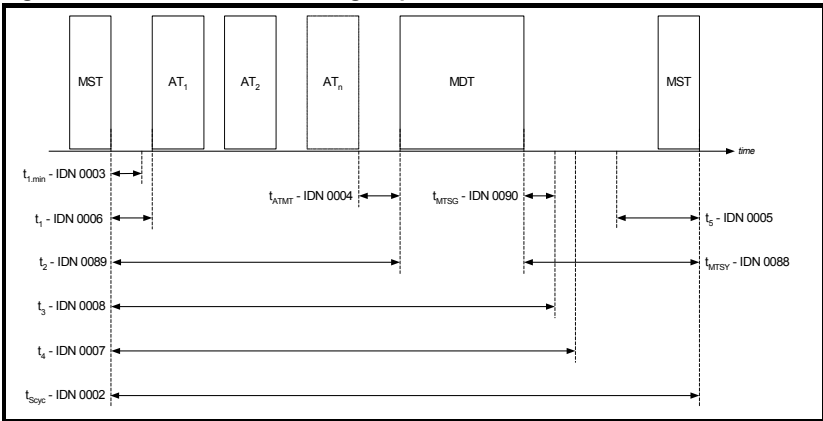

For further details of the SERCOS refer to the official SERCOS web-site at www.sercos.de.

6.2 Supported IDNs

The SM-SERCOS module supports all of the necessary IDNs for class B compliance (with torque, velocity, position control modes, drive-controlled homing and the probe cycle functions). It also supports a variety of additional IDNs. The following is a list of all the IDNs supported by the SM-SERCOS.

6.3 Summary of IDNs

6.3.1 IDN - 00001

Name	Control unit cycle time (t_{Ncyc})				
Size	2 bytes	Units	μ s	Access	RW
Default	1000	Range	250 to 65000		

The control unit cycle time defines the cyclic intervals during which the control unit makes new command values available. The control unit cycle time must be transferred from the master to the slave during CP2 and becomes active in the slave during CP3. The control unit cycle time must be an integer multiple of the communication cycle time (IDN 00002). Values are 250 μ s, 500 μ s, 1ms up to 65ms in 1ms increments - any other value will cause the CP3 transition check to fail.

$t_{Ncyc} = t_{Scyc} * n$ [$n = 1,2,3,4...$]. The ratio of this value and the drive cycle time will determine the number of points for the fine interpolation.

6.3.2 IDN - 00002

Name	Communication cycle time (t_{Scyc})				
Size	2 bytes	Units	μ s	Access	RW
Default	1000	Range	250 to 65000		

The SERCOS network cycle time. Values are 250 μ s, 500 μ s, 1ms up to 65ms in 1ms increments - attempts to set any other value will cause the CP3 transition check to fail. MSTs are transmitted by the master on this timebase. This value shall be transferred from the master to the slave during CP2 and becomes active in the slave during CP3.

6.3.3 IDN - 00003

Name	Shortest AT transmission starting time ($t_{1,min}$)				
Size	2 bytes	Units	μ s	Access	RO
Default	90	Range			

The time required by the SM-SERCOS module from the end of the MST until it is able to transmit its AT. Read by the master during CP2.

6.3.4 IDN - 00004

Name	Transmit/receive transition time (t_{ATMT})				
Size	2 bytes	Units	μ s	Access	RO
Default	10	Range			

The time required by the slave to switch from transmitting the AT to receiving the MDT. This is read by the master in CP2 in order to calculate the starting time for an MST transmission (t_2).

6.3.5 IDN - 00005

Name	Minimum feedback processing time (t_5)				
Size	2 bytes	Units	μs	Access	RO
Default	90	Range			

The master reads this value from the slave axes during CP2. This value specifies the process time required by the slave to acquire the feedback data and make it available to the SERCOS interface. In the case of SM-SERCOS the required process time is 90 μs .

This is read so that the master can synchronise the measurement times of the feedback acquisition capture point, t_4 (IDN 00007) appropriately for all drive axes.

6.3.6 IDN - 00006

Name	AT transmission starting time (t_1)				
Size	2 bytes	Units	μs	Access	RW
Default	90	Range	0 to 65000		

This is the time at which the SM-SERCOS module must transmit its AT after the end of the MST. This value is set by the master during CP2. Each drive will require a different setting for this IDN.

6.3.7 IDN - 00007

Name	Feedback acquisition capture point (t_4)				
Size	2 bytes	Units	μs	Access	RW
Default	0	Range	0 to 65000		

The master sets the acquisition capture point for the slave feedback to be less than or equal to the difference between the communication cycle time (IDN 00002) and the requested minimum feedback processing time (IDN 00005), i.e.

$$t_4 \leq t_{\text{Scyc}} - t_5$$

This is done to ensure that all the slave axes feedback sampling are synchronised.

NOTE The interval between t_4 and t_3 (see IDN 00008) will be checked in the CP3 transition check. If the time t_3 occurs first in the same network cycle, there must be at least 15 μs between t_3 and t_4 . If the t_4 occurs first in the network cycle, there must be at least 5 μs between t_4 and t_3 .

6.3.8 IDN - 00008

Name	Command value valid time (t_3)				
Size	2 bytes	Units	μs	Access	RW
Default	0	Range	0 to 65000		

This is the time point at which the command values (cyclic data) received in the last MDT become available for the drive to use.

NOTE See note below IDN - 00007.

6.3.9 IDN - 00009

Name	Position of data record in MDT				
Size	2 bytes	Units		Access	RW
Default	1	Range	1 to 63331		

This value will be set by the master during CP2. It is used to specify to a slave axis where the start byte position of its MDT data record is, i.e. the section of data it should use.

6.3.10 IDN - 00010

Name	Length of MDT				
Size	2 bytes	Units		Access	RW
Default	4	Range	4 to 65534		

This is the length of the entire MDT (including the control word and service channel for each slave). The actual size of the MDT will depend upon how many slaves devices are on the network and how much cyclic data there is. The actual size of the MDT will be:

- 2 bytes per slave control word.
- 2 bytes per slave service channel.
- Each slave device's cyclic data, (the size of which depends upon the mode of operation and whether any additional cyclic data is included by using Telegram type 7).

6.3.11 IDN - 00011

Name	Class 1 diagnostic				
Size	2 bytes	Units		Access	RO
Default		Range			

This diagnostic IDN provides a reason code for why a drive has tripped and disabled the motor output. The bits supported are as follows:

- Bit 0:** Overload shutdown. Set when an It.AC, It.br or O.Ld1 trip occurs.
- Bit 1:** Amplifier over-temperature shutdown. Set when an O.CtL, O.ht1, O.ht2, O.ht3, Oht2.P or Oht4.P trip occurs.
- Bit 2:** Motor over-temperature shutdown. Set when a th trip occurs.
- Bit 3 and 4:** Not supported.
- Bit 5:** Feedback error. Set when an Enc1 to Enc9, tunE7, tunE1, tunE2 or EnP.Err trip occurs.
- Bit 6:** Error in the communications system. Set when a tunE3 to tunE6 trip occurs.
- Bit 7:** Over-current error. Set when an Ol.AC, Ol.br, PS.10V, PS.24V, thS, Ol.br.P, OlAC.P or OidC.P trip occurs.
- Bit 8:** Over-voltage error. Set when an OV or OV.P trip occurs.
- Bit 9:** Under-voltage error. Set when an UU or ACUU.P trip occurs.
- Bit 10:** Power supply phase error. Set when a Ph, PH.P or PS.P trip occurs.
- Bit 11:** Excessive position deviation. Set when the position error is greater than IDN 00159.
- Bit 12:** Communication error. Set if one of the error bits is set in IDN 00014.
- Bit 13:** Not supported.
- Bit 14:** Reserved.
- Bit 15:** Manufacturer specific error. Set if a bit in IDN 00129 is set.

NOTE Bits 11, 12 are not associated with an actual drive trip condition therefore the drive will not trip and disable the motor when any of these bits are equal to a 1.

Bit 15 will in effect cause a trip as the bits in IDN 00129 are associated with trips.

In system file versions V01.02.00 and after, bit 9 is now set for a UU trip condition.

Safety Information
Introduction
Mechanical Installation
Electrical Installation
Getting started
IDNs
Manufacture IDNs
Control and Status Words
Procedure Commands
Data Synchronisation
Advanced Features
Diagnostics
Quick reference
Glossary Of Terms
Index

6.3.12 IDN - 00012

Name	Class 2 diagnostic				
Size	2 bytes	Units		Access	RO
Default		Range			

This diagnostic IDN defines a drive warning. Not all of the bits contained here are supported. The ones that are, however, correspond to the drive alarm conditions. The following bits are supported:

- Bit 0:** Overload warning. Set when the br.rS (braking resistor overload) or OVLd (motor overload) alarm indications are set.
- Bit 1:** Amplifier over-temperature warning. Set when the Hot alarm indication is set.
- Bit 2 to bit 14:** Reserved or not supported.
- Bit 15:** Manufacturer specific warning. Set if a bit is set in IDN 00181.

6.3.13 IDN - 00013

Name	Class 3 diagnostic				
Size	2 bytes	Units		Access	RO
Default		Range			

This diagnostic IDN contains bits relating to the drive/module status. These are not error conditions. The supported bits are as follows:

- Bit 0:** $n_{\text{feedback}} = n_{\text{command}}$. Set when the velocity feedback is within range of the velocity command.
Also see "Window Velocity" *IDN - 00157* on page 59.
- Bit 1:** $n_{\text{feedback}} = 0$. Set when the velocity feedback is within range of zero.
Also see "Standstill Window" *IDN - 00124* on page 54.
- Bit 2:** $|n_{\text{feedback}}| < |n_x|$. Set when the feedback velocity falls below the velocity threshold n_x
Also see "Velocity Threshold" *IDN - 00125* on page 54.
- Bit 3:** Not supported.
- Bit 4:** Set when the torque feedback exceeds IDN 00092.
- Bit 5:** $|n_{\text{command}}| > |n_{\text{Limit}}|$. Set when IDN 00036 + IDN 00037 exceeds IDN 00091
- Bit 6:** In Position. Set when IDN 00047 - IDN 00051 is less than IDN 00057.
- Bit 7 to Bit 14:** Reserved or not supported.
- Bit 15:** Manufacturer specific operation status. Set if a bit is set in IDN 00182.

6.3.14 IDN - 00014

Name	Interface status				
Size	2 bytes	Units		Access	RO
Default		Range			

When the SERCOS communications are ok then bits 0 to 2 contain the actual communications phase number.

If an error occurs, then the following bits will be set as appropriate, in addition to this, bit 12 of IDN 00011 will also be set:

- Bit 0 to Bit 2:** Communication phase number.
- Bit 3:** MST failure.
- Bit 4:** MDT failure.
- Bit 5:** Invalid phase.
- Bit 6:** Error during phase downshift (not to phase 0).
- Bit 7:** Error during phase upshift (invalid sequence).
- Bit 8:** Phase switching without ready acknowledge.
- Bit 9:** Switching to uninitialised operation mode.
- Bit 10:** Drives with the same address in the ring.
- Bit 11:** Not supported.
- Bit 12 to Bit 15:** Reserved.

6.3.15 IDN - 00015

Name	Telegram type parameters				
Size	2 bytes	Units		Access	RW
Default	4	Range	0 to 7		

Defines the format of the AT and MDT. This is set by the master in CP2. The supported telegram types are as follows:

- Type 0:** No cyclic data.
- Type 1:** MDT - Torque command value. AT - No cyclic data.
- Type 2:** MDT - Velocity command value. AT - Velocity feedback value.
- Type 3:** MDT - Velocity command value. AT - Position feedback value.
- Type 4:** MDT - Position command value. AT - Position feedback value.
- Type 5:** MDT - Position and velocity command values. AT - Position and velocity feedback values.
- Type 6:** MDT - Velocity command value. AT - No cyclic data.
- Type 7:** User-defined data (See IDNs 00016 and 00024 for data contents).

NOTE Bit 3 is used to select position feedback (1 or 2) in the telegrams that return position feedback (except telegram type 7). This does not affect the source used for the SM-SERCOS APC.

Safety Information
Introduction
Mechanical Installation
Electrical Installation
Getting started
IDNs
Manufacture IDNs
Control and Status Words
Procedure Commands
Data Synchronisation
Advanced Features
Diagnostics
Quick reference
Glossary Of Terms
Index

6.3.16 IDN - 00016

Name	Configuration list of AT				
Size	Variable	Units		Access	RW
Default		Range			

This IDN is set by the master during CP2, but only if telegram type 7 is selected in IDN 00015 (specifies the IDNs when telegram type 7 is selected). However, the IDNs must be listed under IDN 00187; no other IDNs are allowed.

During the CP3 transition check a comparison is made between this IDN and IDN 00187, if IDN 00016 contains IDNs that are not listed within IDN 00187 the transition check will fail.

When using this IDN check that the total data length of these additional IDNs does not exceed that set in IDN 00185 (this is checked in the CP3 transmission cycle).

6.3.17 IDN - 00017

Name	IDN-list of all operation data				
Size	236 bytes	Units		Access	RO
Default		Range			

This lists all of the operation data IDNs (excluding procedure commands) supported by the SM-SERCOS module.

NOTE This IDN does not include manufacturer specific IDNs as SM-SERCOS contains such a large number of these.

6.3.18 IDN - 00018

Name	IDN-list of operation data for CP2				
Size	28 bytes	Units		Access	RO
Default		Range			

This is a list of operational IDNs that the master must set during CP2:

- 00001 Control unit cycle time.
- 00002 Communication cycle time.
- 00006 AT transmission starting time.
- 00007 Feedback acquisition capture point.
- 00008 Command value valid time.
- 00009 Position of data record in MDT.
- 00010 Length of MDT.
- 00015 Telegram type parameter.
- 00032 Primary operation mode.
- 00033 Secondary operation mode 1.
- 00088 Receive to receive recovery time.
- 00089 MDT transmission starting time.

NOTE IDNs 00016 and 00024 are also required when telegram type 7 is set in IDN 00015.

6.3.19 IDN - 00019

Name	IDN-list of operation data for CP3				
Size	0	Units		Access	RO
Default		Range			

This is a list of operational IDNs that the master must set during CP3.

Currently the SM-SERCOS does not require any operational IDNs to be set during CP3 and this list is inactive.

6.3.20 IDN - 00021

Name	IDN-list of invalid operation data, CP2				
Size	Variable	Units		Access	RO
Default		Range			

This IDN is used during the CP2 to CP3 transition check (see "IDN - 00127" on page 55) to list any of the IDNs that should have been set during CP2 (as listed in IDN 00018) that failed.

6.3.21 IDN - 00022

Name	IDN-list of invalid operation data, CP3				
Size	Variable	Units		Access	RO
Default		Range			

This IDN is used during the CP3 to CP4 transition check (see "IDN - 00128" on page 55) to list any of the IDNs that should have been set during CP3 (as listed in IDN 00019) that failed.

Currently the SM-SERCOS does not require any operational IDNs to be set during CP3 and therefore no failure should be reported.

6.3.22 IDN - 00024

Name	Configuration list of MDT				
Size	2,Variable	Units		Access	RW
Default		Range			

This IDN is set by the master during CP2, but only if telegram type 7 is selected in IDN 00015, this then specifies the IDNs used when using telegram type 7. However, the IDNs must be listed under IDN 00188; no other IDNs are allowed.

During the CP3 transition check, a comparison is made between this IDN and IDN 00188, if IDN 00024 contains IDNs that are not listed within IDN 00188 the transition check will fail.

When using this IDN check that the total data length of these additional IDNs does not exceed that set in IDN 00186. This is also checked during the CP3 transition check.

6.3.23 IDN - 00025

Name	IDN-list of all procedure commands				
Size	16 bytes	Units		Access	RO
Default		Range			

This IDN contains a list of procedure command IDNs supported by SM-SERCOS, which are as follows:

- 00099** Reset class 1 diagnostic.
- 00127** CP3 transition check.
- 00128** CP4 transition check.
- 00148** Drive-controlled homing procedure command.
- 00170** Probing cycle procedure command.
- 00191** Cancel reference point procedure command.

See *Procedure Commands* on page 76 for details on each supported procedure command.

6.3.24 IDN - 00028

Name	MST error counter				
Size	2 bytes	Units		Access	RO
Default		Range	0 to 65535		

This IDN is used to count invalid MSTs in CP3 and CP4. If two consecutive invalid MSTs are detected, all future MSTs will not be counted and the SM-SERCOS will return to CP0 and will disable the drive. This value is reset to zero on a transition from CP2 to CP3.

6.3.25 IDN - 00029

Name	MDT error counter				
Size	2 bytes	Units		Access	RO
Default		Range	0 to 65535		

This IDN is used to count invalid MDTs during CP4. If two consecutive invalid MDTs are detected, all future MDTs will not be counted and the SM-SERCOS will return to CP0 thus disabling the drive. This value is reset to zero on a transition from CP2 to CP3.

6.3.26 IDN - 00030

Name	Manufacturer version				
Size	50 bytes	Units		Access	RO
Default		Range			

This IDN contains a string that is made up from the module name and its system file version, the drive type and its firmware version number, e.g.

“CT SM-SERCOS V01.00.00. Unidrive SP V01.07.01.”

The SM-SERCOS version number is derived from Pr **MM.02** and Pr **MM.51**. The drive version number is derived from Pr **11.29** and Pr **11.34**.

6.3.27 IDN - 00032

Name	Primary operation mode				
Size	2 bytes	Units		Access	RW
Default	3	Range	See IDN 00292		

This IDN is set by the master during CP2 and is used to set the SM-SERCOS primary mode of operation. Only the modes listed in IDN 00292 will be available to be set. The primary or secondary mode selection is controlled in the MDT control word.

6.3.28 IDN - 00033

Name	Secondary operation mode 1				
Size	2 bytes	Units		Access	RW
Default	3	Range	See IDN 00292		

This IDN is set by the master during CP2 and is used to set the SM-SERCOS secondary mode of operation. Only the modes listed in IDN 00292 will be available to be set. The primary or secondary mode selection is controlled in the MDT control word.



Care should be taken when switching between primary and secondary operation modes when the drive is enabled.

6.3.29 IDN - 00036

Name	Velocity command value				
Size	4 bytes	Units	See IDN 00044	Access	RW
Default	0	Range	See IDN 00044		

The velocity reference in velocity control mode. If bit 0 in IDN 00043 is set, the value will be negated. This will be written to the hard speed reference parameter or the position controller external speed feedforward after being summed with IDN 00037 and then converted to the drive internal units (encoder counts / 250µs). In velocity control mode, this value (scaled) will also be written to the user hard speed reference parameter during the background task to give a user indication.

6.3.30 IDN - 00037

Name	Additive velocity command value				
Size	4 bytes	Units	See IDN 00044	Access	RW
Default	0	Range	See IDN 00044		

This IDN is used when operating a slave axis in velocity control mode and is used to add a velocity offset. The value of this offset will be added to the value of IDN 00036 by the slave.

6.3.31 IDN - 00040

Name	Velocity feedback value 1				
Size	4 bytes	Units	See IDN 00044	Access	RO
Default		Range	See IDN 00044		

The SM-SERCOS sources the speed feedback direct from the drive speed loop as it is quicker than Pr 3.02 (which is only updated every 4ms) This value is then transferred from the slave to the master as part of the AT cyclic data.

6.3.32 IDN - 00041

Name	Homing velocity				
Size	4 bytes	Units	See IDN 00044	Access	RW
Default	4096	Range	See IDN 00044		

The homing velocity is used during the drive controlled homing procedure command (IDN 00148). When enabled the drive then performs its own homing routine.

6.3.33 IDN - 00042

Name	Homing acceleration				
Size	4 bytes	Units	See IDN 00160	Access	RW
Default	65536	Range	See IDN 00160		

The homing acceleration is used during the drive controlled homing procedure command (IDN 00148). When enabled the drive then performs its own homing routine.

6.3.34 IDN - 00043

Name	Velocity polarity parameter				
Size	2 bytes	Units		Access	RW
Default	0	Range			

The IDN invert bits of this IDN are used to change the sign of the velocity data going into the drive speed loop, it will also change the sign of the data produced by the drive speed loop.

A positive velocity with no inversion programmed here means that the motor shaft will rotate in a clockwise direction (as viewed from the motor shaft).

- Bit 0:** Velocity command value (IDN 00036)
0 - Non-inverted
1 - Inverted
- Bit 1:** Additive velocity command value (IDN 00037)
0 - Non-inverted
1 - Inverted
- Bit 2:** Velocity feedback value 1 (IDN 00040)
0 - Non-inverted
1 - Inverted
- Bit 3 to Bit 15:** Reserved or not supported

6.3.35 IDN - 00044

Name	Velocity data scaling type				
Size	2 bytes	Units		Access	RO
Default	0	Range			

The SM-SERCOS does not use any scaling, therefore the value of this IDN is fixed. As there is no scaling all velocity related IDN values are specified in encoder counts per second, such as:

- The bipolar velocity limit (IDN 00091).
- The standstill window (IDN 00124).
- The velocity threshold (IDN 00125).
- The velocity window (IDN 00157).

NOTE E.g. The maximum rpm rating of the Unidrive SP is 40,000rpm, therefore all velocity data values will have a range of \pm MAX, where MAX is the equivalent of the \pm 40,000rpm in encoder counts per second the value of which will depend upon the resolution of the feedback device used and the number of turn bits set in Pr **MM.43** (see Chapter 5.4.8 *Encoder turn bits* on page 26).

6.3.36 IDN - 00045

Name	Velocity data scaling factor				
Size	2 bytes	Units		Access	RO
Default	1	Range			

Defines the scaling factor for all velocity data. This is fixed at a value of 1.

6.3.37 IDN - 00046

Name	Velocity data scaling exponent				
Size	2 bytes	Units		Access	RO
Default	0	Range			

Defines the scaling exponent for all velocity data. This is fixed at a value of 0.

6.3.38 IDN - 00047

Name	Position command value				
Size	4 bytes	Units	See IDN 00076	Access	RW
Default	0	Range	-2^{31} to $+2^{31}-1$		

This IDN is used by the master during CP4 to send the slave axes that are operating in position control mode their position references.

The SM-SERCOS will convert and if necessary interpolate this data (depending if the master and network cycle times are different to the drive, i.e. 250 μ s) and pass it into the SM-SERCOS position controller.

Safety Information
Introduction
Mechanical Installation
Electrical Installation
Getting started
IDNs
Manufacture IDNs
Control and Status Words
Procedure Commands
Data Synchronisation
Advanced Features
Diagnostics
Quick reference
Glossary Of Terms
Index

6.3.39 IDN - 00051

Name	Position feedback value				
Size	4 bytes	Units	See IDN 00076	Access	RW
Default		Range	-2 ³¹ to +2 ³¹ -1		

The SM-SERCOS sources the position feedback direct from the drive encoder input or optional Solutions Module feedback device as selected by Pr **MM.42**. This value is then transferred from the slave to the master as part of the AT cyclic data.

6.3.40 IDN - 00052

Name	Reference distance 1				
Size	4 bytes	Units	See IDN 00076	Access	RW
Default	0	Range	-2 ³¹ to +2 ³¹ -1		

This IDN is used during the drive controlled homing procedure (see *IDN - 00148* on page 58). Once a homing command has been initiated the SM-SERCOS monitors the position feedback marker pulse.

6.3.41 IDN - 00053

Name	Position feedback value 2 (external feedback)				
Size	4 bytes	Units	See IDN 00076	Access	R
Default	0	Range	-2 ³¹ to +2 ³¹ -1		

This IDN is provided to allow access to a second encoder (if installed) for applications requiring one and a half axis control. It can be used for cyclic or non-cyclic position feedback, but cannot be used by the SERCOS APC (position control) as a feedback source. This IDN will be mapped to the position feedback selected by Pr **MM.11** (second encoder source), the value will be negated if bit 3 in IDN 00055 is set and the value will be zeroed if the second encoder is disabled in Pr **MM.10** (second encoder enable). Pr **MM.12** (second encoder turn bits) will specify the number of turn bits in the external encoder position.

6.3.42 IDN - 00055

Name	Position polarity parameters				
Size	2 bytes	Units		Access	RW
Default	0	Range			

The IDN invert bits of this IDN are used to change the sign of the position data going into the position loop, it will also change the sign of the data produced by the SM-SERCOS position loop.

Moving from a negative or zero position value to a positive position value, with no inversion programmed here, will cause the motor shaft to rotate in a clockwise direction (as viewed from the motor shaft).

Bit 0: Position command value (IDN 00047)

- 0 - Non-inverted
- 1 - Inverted

Bit 1: Not supported

Bit 2: Position feedback value 1 (IDN 00051).

- 0 - Non-inverted
- 1 - Inverted

Bit 3: Position feedback value 2 (IDN 00053).

- 0 - Non-inverted
- 1 - Inverted

**Bit 4 to
Bit 15:** Reserved or not supported

6.3.43 IDN - 00057

Name	Position window				
Size	4 bytes	Units	See IDN 00076	Access	RW
Default	0	Range	0 to $+2^{32}$		

When the position feedback value is within a range of the position command value defined by this IDN, the "In Position" bit in the class 3 diagnostic IDN is set, otherwise the bit is cleared. This IDN defines the distance either side of the position command value.

6.3.44 IDN - 00076

Name	Position data scaling type				
Size	2 bytes	Units		Access	RO
Default	0	Range			

SM-SERCOS does not use any scaling for position data, therefore the value of this IDN will always be 0. As there is no scaling the position is defined as a combination of encoder revolutions, coarse position and fine position. See *Encoder turn bits* on page 26 for further details.

6.3.45 IDN - 00079

Name	Rotational position resolution				
Size	4 bytes	Units		Access	RO
Default		Range	1 to $+2^{32}-1$		

This IDN defines the resolution for all rotational position data. The value represents the number of encoder counts in one revolution which is derived from the number of turn bits Pr **MM.43**. See *Encoder turn bits* on page 26 for further details.

6.3.46 IDN - 00080

Name	Torque command value				
Size	2 bytes	Units	See IDN 00086	Access	RW
Default	0	Range	-10000 to +10000		

This IDN is used by the master during CP4 to send the slave axes that are operating in torque control mode their torque references.

The SM-SERCOS will pass this value to the drive torque reference Pr **4.08**.

6.3.47 IDN - 00081

Name	Additive torque command value				
Size	2 bytes	Units	See IDN 00086	Access	RW
Default	0	Range	-10000 to +10000		

This IDN is used when operating a slave axis in torque control mode and is used to add a torque offset. The value of this offset will be added to the value of IDN 00080 by the slave.

6.3.48 IDN - 00084

Name	Torque feedback value				
Size	2 bytes	Units	See IDN 00086	Access	RW
Default		Range	-10000 to +10000		

This IDN does not quite function as its name implies. It returns the sum of IDN 00080 added to IDN 00081. This value is then transferred from the slave to the master as part of the AT cyclic data, the calculation is as follows:

$$IDN\ 00084 = IDN\ 00080 + IDN\ 00081$$

6.3.49 IDN - 00085

Name	Torque polarity parameter				
Size	2 bytes	Units		Access	RW
Default	0	Range			

The IDN invert bits of this IDN are used to change the sign of the torque data going into the drive current loop, it will also change the sign of the data produced by the drive current loop.

A positive torque when the motor shaft is not moving, with no inversion programmed, will cause the motor shaft to rotate in a clockwise direction (as viewed from the motor shaft):

- Bit 0:** Torque command value (IDN 00080)
0 - Non-inverted
1 - Inverted
- Bit 1:** Additive torque command value (IDN 00081)
0 - Non-inverted
1 - Inverted
- Bit 2:** Torque feedback value 1(IDN 00084)
0 - Non-inverted
1 - Inverted
- Bit 3 to Bit 15:** Reserved or not supported

6.3.50 IDN - 00086

Name	Torque/force data scaling type				
Size	2 bytes	Units		Access	RO
Default	0	Range			

The SM-SERCOS only uses percentage scaling for torque values, therefore the value of this IDN will always be 0. All of the torque related IDN values are specified in units of 0.1% of the motor rated torque, for example:

A torque value of 105 = 10.5%.

6.3.51 IDN - 00088

Name	Receive to receive recovery time ($t_{M\text{TSY}}$)				
Size	2 bytes	Units	μs	Access	RO
Default	10	Range			

The master reads this value from the slave axes during CP2. The value of this IDN specifies the time required by a slave between the receipt of the MDT and the next MST.

6.3.52 IDN - 00089

Name	MDT transmission starting time (t_2)				
Size	2 bytes	Units	μs	Access	RW
Default	0	Range	0 to t_{Scyc}		

The master writes this value to the slave axes during CP2. The value of this IDN specifies the time at which the master will transmit the MDT during CP3 and CP4. It is then used by the slaves to check that the MDT is received on time.

Safety Information
Introduction
Mechanical Installation
Electrical Installation
Getting started
IDNs
Manufacture IDNs
Control and Status Words
Procedure Commands
Data Synchronisation
Advanced Features
Diagnostics
Quick reference
Glossary Of Terms
Index

6.3.53 IDN - 00090

Name	Command value proceeding time (t_{MTSG})				
Size	2 bytes	Units	μ S	Access	RO
Default	10	Range			

The master reads this value from the slave axes during CP2 to calculate a valid time value for t_3 (IDN 0003). The value of this IDN specifies the time period required by the SM-SERCOS module to process the cyclic data received in the MDT. Once the cyclic data / command values have been processed they will be executed between the time periods t_3 and t_4 .

6.3.54 IDN - 00091

Name	Bipolar velocity limit value				
Size	4 bytes	Units	See IDN 00044	Access	RW
Default	3276800	Range	See IDN 00044		

This is the maximum allowed velocity in the positive or negative direction. This value is checked by the SM-SERCOS module and if it is exceeded, bit 5 in the class 3 diagnostic IDN will be set.

6.3.55 IDN - 00092

Name	Bipolar torque limit value				
Size	2 bytes	Units	See IDN 00086	Access	RW
Default	10000	Range	0 to +10000		

This is the maximum allowed torque in the positive or negative direction. This value is checked by the SM-SERCOS module and if it is exceeded, bit 4 in the class 3 diagnostic IDN will be set.

6.3.56 IDN - 00095

Name	Diagnostic message				
Size	Variable	Units		Access	RO
Default		Range			

This IDN contains a string relating to the status of the SM-SERCOS module. It will contain one of the following messages:

Status	IDN 00095 message string
After entering CP2:	"Communication phase 2 ready"
After entering CP3:	"Communication phase 3 ready"
After entering CP4:	"Communication phase 4 ready"
After procedure command 99 has finished:	"No Error"
IDN 00014 Bit 3 is set:	"Error: MST failure"
IDN 00014 Bit 4 is set:	"Error: MDT failure"
IDN 00014 Bit 5 is set:	"Error: Invalid phase"
IDN 00014 Bit 6 is set:	"Error during phase upshift"
IDN 00014 Bit 7 is set:	"Error during phase downshift"
IDN 00014 Bit 8 is set:	"Error: Phase switching without ready acknowledge"
IDN 00014 Bit 10 is set:	"Error: 2 drives with same address in the ring".
If an optical fiber break has occurred:	"Error: optical fiber break"
If the SERCON DPRAM fails to be initialised:	"Error on SERCON initialisation"

6.3.57 IDN - 00096

Name	Slave arrangement (SLKN)				
Size	2 bytes	Units		Access	RO
Default		Range			

If used, the master reads this value from the slaves during CP2. The SM-SERCOS can only be used with a drive which is a single axis drive therefore this IDN will return the SM-SERCOS network address in each byte, e.g. 101_{HEX} or 257_{DEC}

6.3.58 IDN - 00097

Name	Mask class 2 diagnostic				
Size	2 bytes	Units		Access	RW
Default	0	Range			

This IDN contains mask bits that are directly related to the class 2 diagnostic IDN 00012. However, clearing a mask bit does not disable the equivalent diagnostic bit, it just prevents that bit causing the class 2 change bit in the AT status word from being set (see *AT Status word* on page 75). This is set to zero by default.

6.3.59 IDN - 00098

Name	Mask class 3 diagnostic				
Size	2 bytes	Units		Access	RW
Default	0	Range			

This IDN contains mask bits that are directly related to the class 3 diagnostic IDN 00013. However, clearing a mask bit does not disable the equivalent diagnostic bit, it just prevents that bit causing the class 3 change bit in the AT status word from being set (see *AT Status word* on page 75). This is set to zero by default.

6.3.60 IDN - 00099

Name	Reset class 1 diagnostic				
Size	2 bytes	Units		Access	RW
Default		Range			

This IDN when set will reset the following:

- Class 1 diagnostic (IDN 00011).
- Interface error (IDN 00014).
- Manufacturer class 1 diagnostic (IDN 00129).
- Drive shut down bit (AT status word bit 13).
- Will attempt to clear a drive trip.

This will be possible if there is no active trip condition currently set in the drive (and no other error condition that would cause bits to be set in the above IDNs).

6.3.61 IDN - 00100

Name	Velocity loop proportional gain				
Size	2 bytes	Units	10^{-4} (1/rads ⁻¹)	Access	RW
Default		Range	0 to 65535		

The value of this IDN is mapped directly to the drive speed loop proportional gain Pr **3.10**. The drive has multiple sets of PID gains but it is only possible to control the primary set over the SERCOS network, therefore the gain selector Pr **3.16** should be set to 0.

NOTE Control of the secondary PID gains is possible using the manufacturer specific IDNs.

6.3.62 IDN - 00101

Name	Velocity loop integral gain				
Size	2 bytes	Units	10^{-2} (1/rads)	Access	RW
Default		Range	0 to 65535		

The value of this IDN is mapped directly to the drive speed loop integral gain Pr **3.11**. The drive has multiple sets of PID gains but it is only possible to control the primary set over the SERCOS network, therefore the gain selector Pr **3.16** should be set to 0.

NOTE Control of the secondary PID gains is possible using the manufacturer specific IDNs.

6.3.63 IDN - 00102

Name	Velocity loop differential time				
Size	2 bytes	Units	10^{-5} s	Access	RW
Default		Range	0 to 65535		

The value of this IDN is mapped directly to the drive speed loop differential gain Pr 3.12. The drive has multiple sets of PID gains but it is only possible to control the primary set over the SERCOS network, therefore the gain selector Pr 3.16 should be set to 0.

NOTE This value is a time and not a gain.

6.3.64 IDN - 00103

Name	Modulo value				
Size	4 bytes	Units	See IDN 00076	Access	RW
Default	65536	Range	1 to $2^{32}-1$		

Specifies the range of positions allowed when bit 7 is set in IDN 00076 (position data scaling type).

6.3.65 IDN - 00104

Name	Position loop Kv-factor				
Size	2 bytes	Units	10^{-4}	Access	RW
Default	2500	Range	0 to 65535		

The position loop proportional gain. This is mapped directly to the SM-SERCOS position controller.

6.3.66 IDN - 00106

Name	Current loop proportional gain 1				
Size	2 bytes	Units		Access	RW
Default		Range	0 to 30000		

The value of this IDN is mapped directly to the drive Pr 4.13.

6.3.67 IDN - 00107

Name	Current loop integral gain 1				
Size	2 bytes	Units		Access	RW
Default		Range	0 to 30000		

The value of this IDN is mapped directly to the drive Pr 4.14.

6.3.68 IDN - 00109

Name	Motor peak current				
Size	4 bytes	Units	mA	Access	RO
Default		Range	0 to $2^{32}-1$		

The value of this IDN is the product of Pr 4.18 (the overriding current limit, a percentage) and Pr 5.07 (the motor rated current, in Amps) and is scaled to mA by SM-SERCOS.

6.3.69 IDN - 00110

Name	Amplifier peak current				
Size	4 bytes	Units	mA	Access	RO
Default		Range	0 to $2^{32}-1$		

The value of this IDN is derived from Pr **11.32** but is multiplied by 2.2 (the maximum drive current) scaled to mA by *SM-SERCOS*.

6.3.70 IDN - 00112

Name	Amplifier rated current				
Size	4 bytes	Units	mA	Access	RO
Default		Range	0 to $2^{32}-1$		

The value of this IDN is derived from Pr **11.32** but is scaled to mA by *SM-SERCOS*.

6.3.71 IDN - 00114

Name	Load limit of the motor				
Size	4 bytes	Units	mA	Access	RO
Default		Range	0 to $2^{32}-1$		

The value of this IDN is derived from Pr **5.07** but is scaled to mA by *SM-SERCOS*. The overload warning bit in the class 2 diagnostic (IDN 00012) is set once the drive Pr **10.17** (Overload alarm) is set. See the *relevant drive advanced user guide* for details on how the I^2t alarm operates.

6.3.72 IDN - 00124

Name	Standstill window				
Size	4 bytes	Units	See IDN 00044	Access	RW
Default	0	Range	See IDN 00044		

This IDN is used when detecting the zero speed condition. This value is checked by the *SM-SERCOS* module and if the magnitude of the difference between zero speed and the velocity feedback is less than this IDN, then bit 1 in the class 3 diagnostic (IDN 00013) will be set.

6.3.73 IDN - 00125

Name	Velocity threshold				
Size	4 bytes	Units	See IDN 00044	Access	RW
Default	0	Range	See IDN 00044		

This IDN is used when detecting the velocity threshold. This value is checked by the *SM-SERCOS* module and if the velocity falls below this value, bit 2 in class 3 diagnostic (IDN 00013) will be set.

6.3.74 IDN - 00127

Name	CP3 Transition check				
Size	2 bytes	Units		Access	RW
Default		Range			

This IDN is used to check that the SM-SERCOS module and drive are ready to enter CP3. The master must execute this procedure command before entering CP3. If the drive/module is ready to enter CP3, it will give a positive acknowledgement to the procedure command. If it is not ready, it will give an acknowledgement "*procedure command not yet executed*". If some of the required IDNs have not been set (see IDN 00018), it will give a negative acknowledgement "*Error, procedure command execution impossible*", and a list of the IDNs that are still required will be placed in the list IDN 00021.

6.3.75 IDN - 00128

Name	CP4 Transition check				
Size	2 bytes	Units		Access	RW
Default		Range			

This IDN is used to check that the SM-SERCOS module and drive are ready to enter CP4. The master must execute this procedure command before entering CP4. If the drive/module is ready to enter CP4, it will give a positive acknowledgement to the procedure command. If it is not ready, it will give an acknowledgement "*procedure command not yet executed*". If some of the required IDNs have not been set (see IDN 00019), it will give a negative acknowledgement "*Error, procedure command execution impossible*", and a list of the IDNs that are still required will be placed in IDN 00022. The negative acknowledgement will also be given if the module is not the synchronisation master (or if its synchronisation signal is not within the correct specification).

Safety Information
Introduction
Mechanical Installation
Electrical Installation
Getting started
IDNs
Manufacture IDNs
Control and Status Words
Procedure Commands
Data Synchronisation
Advanced Features
Diagnostics
Quick reference
Glossary Of Terms
Index

6.3.76 IDN - 00129

Name	Manufacturer class 1 diagnostic				
Size	2 bytes	Units		Access	RO
Default		Range			

This diagnostic IDN provides a reason code for why a drive has tripped and disabled the motor output. It specifies other errors that are more specific to the Unidrive SP/Digitax ST not covered by the error codes in the Class 1 diagnostic (IDN 00011). These are all drive trips:

- Bit 0:** User Error. Set when a trip t010, t038, t040 to t089, t099, t111 to t160, t168 to t175 or a t216 occurs.
- Bit 1:** User Program Error. Set when a trip UP div0, UP Par, UP ro, UP So, UP ovr, UP OFL, UP uSEr, UP udf or a UP ACC occurs.
- Bit 2:** Solutions Module Error. Set when a trip SL1.HF, SL1.To, SL1.Er, SL1.nF, SL1.dF, SL2.HF, SL2.tO, SL2.Er, SL2.nF, SL2.dF, SL3.HF, SL3.tO, SL3.Er, SL3.nF, SL3.dF or a SL.rtd occurs.
- Bit 3:** Smartcard Error. Set when a trip C.Boot, C.BUusy, C.Chg, C.Optn, C.RdO, C.Err, C.dat, C.FULL, C.Acc, C.rtg, C.Typ or a C.cpr occurs.
- Bit 4:** Hardware Error. Set when a trip HF17 to HF32 occurs.
- Bit 5:** Miscellaneous Error. Set when a trip PS, Et, OSPd, tunE, cL2, cL3, SCL, EEF, rS, PAd, CL.bit, SAVE.Er, PSAVE.Er, L.SYNC, Unid.P or a dESt occurs.
- Bit 6:** Set if any other trip code occurs.
- Bit 7 to Bit 15:** Reserved or not supported.

6.3.77 IDN - 00130

Name	Probe value 1 positive edge				
Size	4 bytes	Units	See IDN 00076	Access	RO
Default		Range	-2 ³¹ to +2 ³¹ -1		

This will contain the position value saved when a positive edge occurred at the probe 1 input and the probe cycle procedure command is active, the probe 1 enable bit is set and bit 0 in the probe control parameter (IDN 00169) is set.

6.3.78 IDN - 00131

Name	Probe value 1 negative edge				
Size	4 bytes	Units	See IDN 00076	Access	RO
Default		Range	-2 ³¹ to +2 ³¹ -1		

This will contain the position value saved when a negative edge occurred at the probe 1 input only when the probe cycle procedure command is active, the probe 1 enable bit is set and bit 1 in the probe control parameter (IDN 00169) is set.

6.3.79 IDN - 00132

Name	Probe value 2 positive edge				
Size	4 bytes	Units	See IDN 00076	Access	RO
Default		Range	-2 ³¹ to +2 ³¹ -1		

This will contain the position value saved when a positive edge occurred at the probe 2 input and the probe cycle procedure command is active, the probe 2 enable bit is set and bit 2 in the probe control parameter (IDN 00169).

6.3.80 IDN - 00133

Name	Probe value 2 negative edge				
Size	4 bytes	Units	See IDN 00076	Access	RO
Default		Range	-2 ³¹ to +2 ³¹ -1		

This will contain the position value saved when a negative edge occurred at the probe 2 input and the probe cycle procedure command is active, the probe 2 enable bit is set and bit 3 in the probe control parameter (IDN 00169) is set.

6.3.81 IDN - 00134

Name	MDT control word				
Size	2 bytes	Units		Access	RO
Default		Range			

This IDN value will contain the value of the last control word received in the master from the MDT.

6.3.82 IDN - 00135

Name	AT status word				
Size	2 bytes	Units		Access	RO
Default		Range			

This IDN value will contain the current value of the status word to be transmitted to the master in the AT (but not including the service channel status bits, which are generated by the SM-SERCOS hardware).

6.3.83 IDN - 00138

Name	Bipolar acceleration limit value				
Size	4 bytes	Units	See IDN 00160	Access	RW
Default	2147483647	Range	0 to +2 ³² -1		

This IDN value will be used on the speed output of the position controller. If the acceleration generated exceeds this value, it will be limited. This limit applies when operating in the position and velocity modes, but not in torque control mode.

6.3.84 IDN - 00142

Name	Application type				
Size	34 bytes	Units		Access	RO
Default		Range			

This will contain the string "CT SM-SERCOS Slave".

6.3.85 IDN - 00143

Name	SERCOS interface version				
Size	10 bytes	Units		Access	RO
Default		Range			

This IDN specifies the SERCOS version type that the SM-SERCOS conforms to. The data is provided as a string type, i.e. "V02.02".

6.3.86 IDN - 00147

Name	Homing parameter				
Size	2 bytes	Units		Access	RW
Default	260	Range			

This IDN is used to configure the various aspects of the drive controlled homing procedure. The bits are as follows:

- Bit 0:** Homing direction
0 - Positive. Motor shaft turns clockwise
1 - Negative. Motor shaft turns anti-clockwise
- Bit 1:** Position feedback marker pulse
0 - first marker pulse after the positive edge of the home switch
1 - first marker pulse after the negative edge of the home switch
- Bit 2:** Home switch
0 - connected to the control unit
1 - connected to the drive
- Bit 3 to
Bit 4:** Not supported
- Bit 5:** Evaluation of home switch
0 - home switch is evaluated
1 - home switch is not evaluated
- Bit 6 to
Bit 15:** Reserved or not supported, bit 7 set to 1 by default.

6.3.87 IDN - 00148

Name	Drive controlled homing procedure command				
Size	2 bytes	Units		Access	RW
Default		Range			

When the drive controlled homing procedure command is activated, the drive will ignore position, velocity and torque commands. It will accelerate (at the homing acceleration, IDN 00042) up to the homing velocity (IDN 00041). It will continually check the home switch (see *IDN - 00400* on page 68) for an edge. It will save the position value at the first marker pulse after an edge on the switch and it will stop the drive. The distance of a reference point from the axis zero point (IDN 00052), and the distance to the marker position from the reference point (IDN 00150) must be both known in advance. This allows the feedback position value to be changed to a position referenced to the axis zero point. This process is configured using the homing parameter (IDN 00147). The behavior of the homing routine will be determined partially by Pr **MM.15** (see Chapter 11.7 *SM-SERCOS homing backoff behavior* on page 89).

6.3.88 IDN - 00150

Name	Reference offset 1				
Size	4 bytes	Units	See IDN 00076	Access	RW
Default	0	Range	-2 ³¹ to +2 ³¹ -1		

This IDN defines the distance between the reference marker pulse and the reference point. It is used in the drive controlled homing procedure to calculate the new position feedback value relative to the machine zero point.

6.3.89 IDN - 00157

Name	Velocity window				
Size	4 bytes	Units		Access	RW
Default	0	Range	See IDN 00044		

This IDN is used when detecting the difference between the total velocity command value and the velocity feedback. This difference is then checked by the SM-SERCOS module and if the magnitude is less than this IDN the bit 0 in the class 3 diagnostic (IDN 00013) will be set.

6.3.90 IDN - 00159

Name	Monitoring window				
Size	4 bytes	Units	See IDN 00076	Access	RW
Default	2147483647	Range	0 to 2 ³² -1		

This IDN is used to define a maximum allowable position deviation. If the position error (difference between the position command and feedback) exceeds this value, the excessive position error bit 11 in the class 1 diagnostic (IDN 0011) will be set.

6.3.91 IDN - 00160

Name	Acceleration data scaling type				
Size	4 bytes	Units		Access	RO
Default	0	Range	-2 ³¹ to 2 ³¹ -1		

The SM-SERCOS does not use any scaling, therefore the value of this IDN will always be 0. As there is no scaling all of the acceleration data will be specified in units of encoder counts per second per second (counts/second²).

6.3.92 IDN - 00161

Name	Acceleration data scaling factor				
Size	2 bytes	Units		Access	RO
Default	1	Range			

This IDN defines the scaling factor for all acceleration data. This is fixed at a value of 1.

6.3.93 IDN - 00162

Name	Acceleration data scaling exponent				
Size	2 bytes	Units		Access	RO
Default	0	Range			

This IDN defines the scaling exponent for all acceleration data. The is fixed at a value of 0.

6.3.94 IDN - 00169

Name	Probe control parameter				
Size	2 bytes	Units		Access	RW
Default	0	Range			

This specifies the selected probes and edges for the probing cycle procedure command:

- Bit 0:** Probe 1 positive edge
 0 - Positive edge is not active
 1 - Positive edge is active. Position data will be saved in IDN 00130 on the edge trigger.
- Bit 1:** Probe 1 negative edge
 0 - Negative edge is not active
 1 - Negative edge is active. Position data will be saved in IDN 00131 on the edge trigger.
- Bit 2:** Probe 2 positive edge
 0 - Positive edge is not active
 1 - Positive edge is active. Position data will be saved in IDN 00132 on the edge trigger.
- Bit 3:** Probe 2 negative edge
 0 - Negative edge is not active
 1 - Negative edge is active. Position data will be saved in IDN 00133 on the edge trigger.
- Bit 4 to Bit 15:** Reserved or not supported

6.3.95 IDN - 00170

Name	Probing cycle procedure command				
Size	2 bytes	Units		Access	RW
Default		Range			

This IDN can be set by the master to enable the probing cycle procedure, which enables the SM-SERCOS to capture position data when triggered by its two probe inputs. This IDN should be used in conjunction with the following IDNs:

- IDNs 00405 and 00406 are used to enable probe inputs 1 and 2 respectively.
- IDNs 00130 to 00133 are used to store the captured position data depending upon the capture types enabled in IDN 00169.
- IDNs 00409 to 00412 are used to provide a status for each of the probe signal edge triggers.

6.3.96 IDN - 00172

Name	Displacement to the referenced system procedure command				
Size	2 bytes	Units		Access	RW
Default		Range			

When this procedure command is selected, the displacement specified in IDN 00175 (displacement parameter 1) will be added to the position feedback, and IDN 00403 (position feedback value status) will be set to 1. The procedure command will finish when IDN 00404 is given a value of 1 by the controller / SERCOS master.

6.3.97 IDN - 00175

Name	Displacement parameter 1				
Size	4 bytes	Units	See IDN 00076	Access	RW
Default	0	Range	-2 ³¹ to 2 ³¹ -1		

This displacement will be added to the feedback position when the procedure command 'Displacement to the referenced system' (IDN 00172) is executed.

6.3.98 IDN - 00179

Name	Probe status				
Size	2 bytes	Units		Access	RO
Default		Range			

This IDN is used when the probing cycle procedure command is enabled. This IDN duplicates the values in IDNs 00409 to 00412.

When the procedure command is disabled, all of these bits will be cleared.

If the probe 1 enable bit is cleared, the bits 0 and 1 are reset.

If the probe 2 enable bit is cleared, the bits 2 and 3 will be reset:

Bit 0: Probe 1 positive latched - IDN 00409
0 - Not latched
1 - Latched

Bit 1: Probe 1 negative latched - IDN 00410
0 - Not latched
1 - Latched

Bit 2: Probe 2 positive latched IDN 00411
0 - Not latched
1 - Latched

Bit 3: Probe 2 negative latched IND 00412
0 - Not latched
1 - Latched

**Bit 4 to
Bit 15:** Reserved or not supported

6.3.99 IDN - 00181

Name	Manufacturer class 2 diagnostic				
Size	2 bytes	Units		Access	RO
Default		Range			

This IDN is used to display if any IPOSYNC errors occur. If this IDN is set, bit 15 in IDN00012 will also be set.

Bit 1: 0 - No IPOSYNC errors
1 - IPOSYNC errors are occurring due to the IPOSYNC bit in the MDT control word being toggled at incorrect intervals.

6.3.100IDN - 00182

Name	Manufacturer class 3 diagnostic				
Size	2 bytes	Units		Access	RO
Default		Range			

Currently no bits in this IDN are used, however if a bit is set in this IDN, bit 15 in the IDN 00013 will be set.

6.3.101IDN - 00185

Name	Length of the configurable data record in the AT				
Size	2 bytes	Units	Byte	Access	RO
Default	10	Range			

This IDN is used to specify the maximum length of cyclic data that can be configured in the slave AT when using telegram type 7.

6.3.102IDN - 00186

Name	Length of the configurable data record in the MDT				
Size	2 bytes	Units	Byte	Access	RO
Default	10	Range			

This IDN is used to specify the maximum length of cyclic data that can be configured in the master MDT when using telegram type 7.

6.3.103IDN - 00187

Name	IDN-list of configurable data in the AT				
Size	12 bytes	Units		Access	RO
Default		Range			

This IDN lists operational data IDNs that the slave can use as cyclic data feedback values in its AT when using telegram type 7. The IDNs are:

- 00040** Velocity feedback value.
- 00051** Position feedback value.
- 00084** Torque feedback value.
- 00189** Following distance.
- 42001** Application menu 3 read-write integer (Pr **20.01**).
- 42002** Application menu 3 read-write integer (Pr **20.02**).
- 42021** Application menu 3 read-write long integer (Pr **20.21**).
- 42022** Application menu 3 read-write long integer (Pr **20.22**).

For more information on application menu 3 see Chapter 11.18 *Cyclic access to SM-Applications* on page 94.

6.3.104 IDN - 00188

Name	IDN-list of configurable data in the MDT				
Size	10 bytes	Units		Access	RO
Default		Range			

This IDN lists operational data IDNs that the master can use as cyclic data command values in its MDT when using telegram type 7. The IDNs are:

- 00036** Velocity command value.
- 00047** Position command value.
- 00080** Torque command value.
- 42003** Application menu 3 read-write integer (Pr **20.03**).
- 42004** Application menu 3 read-write integer (Pr **20.04**).
- 42023** Application menu 3 read-write long integer (Pr **20.23**).
- 42024** Application menu 3 read-write long integer (Pr **20.24**).

For more information on application menu 3 see Chapter 11.18 *Cyclic access to SM-Applications* on page 94.

6.3.105 IDN - 00189

Name	Following distance				
Size	4 bytes	Units	See IDN 00076	Access	RO
Default		Range	-2 ³¹ to 2 ³¹ -1		

This IDN indicates the current position error. It is obtained from the position command value minus the selected position feedback value, i.e.

$$IDN\ 00189 = IDN\ 00047 - IDN\ 00051$$

6.3.106 IDN - 00191

Name	Cancel reference point procedure command				
Size	2 bytes	Units		Access	RW
Default		Range			

Setting this IDN clears the position feedback status bit (IDN 00403) and the position feedback offset.

NOTE This cancels the effects of the homing routine.

6.3.107 IDN - 00196

Name	Motor rated current				
Size	4 bytes	Units	mA	Access	RO
Default		Range	0 to 2 ³² -1		

The value of this IDN is derived from Pr **5.07** but is scaled to mA by SM-SERCOS.

NOTE Although Pr **5.07** is a RW drive parameter IDN 00196 is only RO and therefore can not be set by the SERCOS master.

6.3.108 IDN - 00206

Name	Drive on delay time				
Size	2 bytes	Units	10^{-4} s	Access	RW
Default	0	Range	0 to 65535		

This IDN is used to specify the time period of the delay used by the MDT control word "Halt / Restart" bit 13.

When the MDT control word "Drive On" bit 15 is set the drive will be enabled and go to a stop state for the duration specified by this IDN. When this time has elapsed the SM-SERCOS will then put the drive in to the condition controlled by the MDT control word "Halt / Restart" bit 13.

6.3.109 IDN - 00207

Name	Drive off delay time				
Size	2 bytes	Units	10^{-4} s	Access	RW
Default	0	Range	0 to 65535		

This IDN is used to specify the time period of the delay used by SM-SERCOS before stopping the drive after the MDT control word "Drive On" bit 15 has been cleared, i.e. set to 0. During this delay period the drive will remain enabled but in a stop state, i.e. full torque available at zero speed.

6.3.110 IDN - 00208

Name	Temperature data scaling type				
Size	2 bytes	Units		Access	RO
Default	0	Range			

The drive only uses °C for units of temperature, therefore the value of this IDN will always be 0.

6.3.111 IDN - 00292

Name	List of supported operation modes				
Size	12 bytes	Units		Access	RO
Default		Range			

This IDN lists the supported modes of operation that can be configured in the primary mode of operation (IDN 00032) and the secondary mode of operation (IDN 00033):

- 0 = No operation mode.
- 1 = Torque control.
- 2 = Velocity control.
- 3 = Position control with following error using position feedback 1.
- 11 = Position control without following error (lagless) (see IDN00296).

6.3.112 IDN - 00296

Name	Velocity feed forward gain				
Size	2 bytes	Units		Access	RW
Default	1000	Range	0 to 2000		

The position loop feed forward gain has a default value of 1000, this equates to a unity gain. In many cases, it will probably not be necessary to adjust this value. If the SERCOS specification is followed strictly, this should have no effect on motion in position control mode with following error. However, because a feed forward can be supplied by the user in this mode, this parameter will still have an effect.

6.3.113 IDN - 00301

Name	Allocation of real-time control bit 1				
Size	2 bytes	Units		Access	RW
Default	S-0-0000	Range	0 to 65535		

This IDN is used as destination selector for the real-time control 1 bit (bit 6) in the MDT control word, i.e. enter the number of the IDN required to be associated with this bit. The following IDNs are the only ones permitted:

- 00400** Home switch.
- 00405** Probe 1 enable.
- 00406** Probe 2 enable.

6.3.114 IDN - 00303

Name	Allocation of real-time control bit 2				
Size	2 bytes	Units		Access	RW
Default	S-0-0000	Range	0 to 65535		

This IDN is used as destination selector for the real-time control 2 bit (bit 7) in the MDT control word, i.e. enter the number of the IDN required to be associated with this bit. The following IDNs are the only ones permitted:

- 00400** Home switch.
- 00405** Probe 1 enable.
- 00406** Probe 2 enable.

Safety Information
Introduction
Mechanical Installation
Electrical Installation
Getting started
IDNs
Manufacture IDNs
Control and Status Words
Procedure Commands
Data Synchronisation
Advanced Features
Diagnostics
Quick reference
Glossary Of Terms
Index

6.3.115 IDN - 00305

Name	Allocation of real-time status bit 1				
Size	2 bytes	Units		Access	RW
Default	S-0-0000	Range	0 to 65535		

This IDN is used as source selector for the real time status 1 bit (bit 6) in the AT status word, i.e. enter the number of the IDN required to be associated with this bit. The following IDNs are the only ones permitted:

- 00400 Home switch.
- 00403 Position feedback value status.
- 00405 Probe 1 enable.
- 00406 Probe 2 enable.
- 00409 Probe 1 positive latch.
- 00410 Probe 1 negative latch.
- 00411 Probe 2 positive latch.
- 00412 Probe 2 negative latch.

6.3.116 IDN - 00307

Name	Allocation of real-time status bit 2				
Size	2 bytes	Units		Access	RW
Default	S-0-0000	Range	0 to 65535		

This IDN is used as source selector for the real-time status 2 bit (bit 7) in the AT status word, i.e. enter the number of the IDN required to be associated with this bit. The following IDNs are the only ones permitted:

- 00400 Home switch.
- 00403 Position feedback value status.
- 00405 Probe 1 enable.
- 00406 Probe 2 enable.
- 00409 Probe 1 positive latch.
- 00410 Probe 1 negative latch.
- 00411 Probe 2 positive latch.
- 00412 Probe 2 negative latch.

6.3.117 IDN - 00376

Name	Baud rate				
Size	2 bytes	Units		Access	RO
Default		Range			

This IDN specifies all of the baud rates supported by the SM-SERCOS module. The definition of each bits is as follows:

- Bit 0:** 2Mbps
1 - Supported.
- Bit 1:** 4Mbps
1 - Supported.
- Bit 2:** 8Mbps
1 - Supported.
- Bit 3:** 16Mbps
1 - Supported.
- Bit 4:** Automatic baudrate recognition
0 - Not Supported.

6.3.118 IDN - 00380

Name	DC bus voltage				
Size	2 bytes	Units	V	Access	RO
Default		Range	0 to 1190		

The value of this IDN is taken directly from the drive Pr **5.05** DC bus voltage.

6.3.119 IDN - 00384

Name	Amplifier temperature				
Size	2 bytes	Units	See IDN 00208	Access	RO
Default		Range	-128 to 127		

The Unidrive SP and Digitax ST have two temperature parameters;

- Stack 1 temperature Pr **7.04**.
- Stack 2 temperature Pr **7.05**.

The SM-SERCOS will monitor both of these parameters and will use the one with the highest value as the source data for this IDN.

6.3.120 IDN - 00390

Name	Diagnostic number				
Size	4 bytes	Units		Access	RO
Default		Range	0 to 2 ³²⁻¹		

During normal operation when the drive and SM-SERCOS are in a ok status this IDN will have a value of 0. If the drive trips this IDN will contain the drive trip code (see the *relevant drive user guide* for code definitions).

6.3.121 IDN - 00393

Name	Command value mode				
Size	2 bytes	Units		Access	RW
Default	2	Range			

This IDN is only relevant when modulo positions are in use. It is used to interpret position commands to determine the appropriate direction of movement. The values are as follows (only bits 0 and 1 are supported):

- 0 = Clockwise** If the new position command is less than the previous position command, the motor will move in a clockwise direction with an overflow through modulo position 0. If the new position command is greater than the previous position, the motor will move clockwise to the new position, with no overflow or underflow.
- 1 = Counter-clockwise** If the new position command is less than the previous position command, the motor will move anti-clockwise to the new position, with no overflow or underflow. If the new position command is less than the previous position, the motor will move in an anti-clockwise direction with an underflow through modulo position 0
- 2 = Shortest path** The motor will always be moved the shortest distance, even if this results in an underflow or overflow. This will be the default behavior, because this is the behavior if a modulo range is not set.
- 3 = Absolute** Within the modulo range. A position underflow or overflow will never occur. The motor will be moved the shortest distance except where the previous condition would be broken. This means that the shaft position will always remain within the modulo range around the position it started in, and will not be allowed to cross over into the adjacent areas.

6.3.122 IDN - 00400

Name	Home switch				
Size	2 bytes	Units		Access	RW
Default	0	Range	0 to 1		

This IDN is used as part of the drive homing procedure set-up. It provides the status of the chosen home switch input. The source of the homing switch input is controlled by Pr **MM.41** and IDN 00147.

NOTE If the controller is selected as the home switch source in IDN00147 the master must write this IDN.

NOTE With system file versions prior to V01.02.00 IDN00400 is not updated from the internal home switch, unless the homing procedure is active.

6.3.123 IDN - 00403

Name	Position feedback value status				
Size	2 bytes	Units		Access	RO
Default		Range	0 to 1		

This IDN is used as part of the drive homing procedure. It provides the status of the position feedback.

0 = The position feedback is not referenced to the machine zero point.

1 = The position feedback is referenced to the machine zero point.

This status bit is cleared when the cancel reference point (IDN 00191) or when the drive home controlled homing procedure is activated. This will also be set when a home has successfully completed.

6.3.124 IDN - 00404

Name	Position command value status				
Size	2 bytes	Units		Access	RW
Default	0	Range	0 to 1		

This IDN is used as part of the drive homing procedure. When set it signals to the drive that all position command values are based on the zero point of the machine.

0 = The position command is not referenced to the machine zero point.

1 = The position command is referenced to the machine zero point.

This bit will be set by the controller / SERCOS master during execution of the procedure command 'Displacement to the referenced system' (IDN 00172).

6.3.125 IDN - 00405

Name	Probe 1 enable				
Size	2 bytes	Units		Access	RW
Default	0	Range	0 to 1		

This IDN is used during the probe cycle procedure to enable the probe 1 input.

0 = Probe 1 is not enabled.

1 = Probe 1 is enabled.

6.3.126 IDN - 00406

Name	Probe 2 enable				
Size	2 bytes	Units		Access	RW
Default	0	Range	0 to 1		

This IDN is used during the probe cycle procedure to enable the probe 2 input.

0 = Probe 2 is not enabled.

1 = Probe 2 is enabled.

6.3.127 IDN - 00409

Name	Probe 1 positive latched				
Size	2 bytes	Units		Access	RO
Default		Range	0 to 1		

This IDN is set when the probe cycle procedure command has been executed, the probe 1 enable bit (IDN 00405) has been set, the appropriate bit is set in IDN 00169 and a positive edge has occurred at the probe 1 input.

Safety Information
Introduction
Mechanical Installation
Electrical Installation
Getting started
IDNs
Manufacture IDNs
Control and Status Words
Procedure Commands
Data Synchronisation
Advanced Features
Diagnostics
Quick reference
Glossary Of Terms
Index

6.3.128 IDN - 00410

Name	Probe 1 negative latched				
Size	2 bytes	Units		Access	RO
Default		Range	0 to 1		

This IDN is set when the probe cycle procedure command has been executed, the probe 1 enable bit (IDN 00405) has been set, the appropriate bit is set in IDN 00169 and a negative edge has occurred at the probe 1 input.

6.3.129 IDN - 00411

Name	Probe 2 positive latched				
Size	2 bytes	Units		Access	RO
Default		Range	0 to 1		

This IDN is set when the probe cycle procedure command has been executed, the probe 2 enable bit (IDN 00406) has been set, the appropriate bit is set in IDN 00169 and a positive edge has occurred at the probe 2 input.

6.3.130 IDN - 00412

Name	Probe 2 negative latched				
Size	2 bytes	Units		Access	RO
Default		Range	0 to 1		

This IDN is set when the probe cycle procedure command has been executed, the probe 2 enable bit (IDN 00406) has been set, the appropriate bit is set in IDN 00169 and a negative edge has occurred at the probe 2 input.

7 Manufacture IDNs

7.1 Drive Parameter Access

7.1.1 Overview

IDNs starting at 32768 and upwards are used for manufacturer specific data access. SM-SERCOS uses IDNs 40000 and upwards to access the drive and SM-Applications module parameters directly using the SERCOS service channel (non-cyclic data).

Parameter attributes, such as read-only bits, etc, will be mapped to the IDNs. When a parameter is accessed using the service channel, any errors occurring in the parameter access will be mapped to an appropriate service channel error.

NOTE For information on using SM-Applications for direct motor control using the SERCOS network see section 11.18 *Cyclic access to SM-Applications* on page 94.

7.1.2 Associating drive parameters to IDNs

To access the drive parameters using IDNs, the required menu must be multiplied by 100 and then added to the parameter number. This number can then be added to 40000 to form the correct IDN.

Example 1 - Accessing drive parameters

- To access drive parameter Pr **1.21** the IDN is "IDN 40121".
- To access drive parameter Pr **20.11** the IDN is "IDN 42011".

7.1.3 Associating SM-Applications parameters to IDNs

With the use of the manufacturer IDNs SM-SERCOS can read and write data non-cyclically to and from the internal registers of an SM-Applications module.

To access the SM-Applications parameters using IDNs, the required menu must be multiplied by 100 and then added to the parameter number. This number can then be added to 40000 to form the correct IDN.

The mapping parameters are shown in Table 7.1.

Table 7.1 SM-Applications parameters

SM-Applications parameters	Lowest SM-Applications slot	Direct to slot 1	Direct to slot 2	Direct to slot 3
_Pxx% PLC Registers	Pr 70.xx	Pr 100.xx	Pr 130.xx	Pr 160.xx
_Qxx% PLC Registers	Pr 71.xx	Pr 101.xx	Pr 131.xx	Pr 161.xx
_Rxx% PLC Registers	Pr 72.xx	Pr 102.xx	Pr 132.xx	Pr 162.xx
_Sxx% PLC Registers	Pr 73.xx	Pr 103.xx	Pr 133.xx	Pr 163.xx
_Txx% PLC Registers	Pr 74.xx	Pr 104.xx	Pr 134.xx	Pr 164.xx
_Uxx% PLC Registers	Pr 75.xx	Pr 105.xx	Pr 135.xx	Pr 165.xx
Local Configuration Parameters	Pr 81.xx	Pr 111.xx	Pr 141.xx	Pr 171.xx
Timer Function Parameters	Pr 85.xx	Pr 115.xx	Pr 145.xx	Pr 175.xx
Digital I/O Parameters	Pr 86.xx	Pr 116.xx	Pr 146.xx	Pr 176.xx
Status Parameters	Pr 88.xx	Pr 118.xx	Pr 148.xx	Pr 178.xx
General Parameters	Pr 90.xx	Pr 120.xx	Pr 150.xx	Pr 180.xx
Fast Access Parameters	Pr 91.xx	Pr 121.xx	Pr 151.xx	Pr 181.xx

NOTE

For information on using SM-Applications for cyclic data transfer see section 11.18 *Cyclic access to SM-Applications* on page 94.

Using parameters Pr **70.xx** to Pr **91.xx** allows data to be exchanged with the SM-Applications installed in the drive's lowest numerical slot number. This method is convenient to use if there is only one SM-Applications installed to the drive as it guarantees that data will always be written to the SM-Applications even if it is moved to a different slot. If two SM-Applications modules are installed it is recommend that the "direct to slot" parameters are used.

Example 2 - Unidrive SP: Single SM-Applications installed

Consider a Unidrive SP with the following configuration:

Slot 1 - Vacant

Slot 2 - SM-Applications.

Slot 3 - SM-SERCOS.

- To access SM-Applications parameter Pr **71.08** (_Q08%) in the Unidrive SP lowest numerical slot the IDN is "IDN 47108".
- To access SM-Applications parameter Pr **131.08** (_Q08%) in the Unidrive SP slot 2 the IDN is "IDN 53108".
- To access SM-Applications parameter Pr **101.08** (_Q08%) in the Unidrive SP slot 1 the IDN is "IDN 50108". However, as there is no SM-Applications installed in slot 1 an error message will be returned indicating that the parameter does not exist.

Example 3 - Unidrive SP: Dual SM-Applications installed

Consider a Unidrive SP with the following configuration:

Slot 1 - SM-Applications.

Slot 2 - SM-Applications.

Slot 3 - SM-SERCOS.

- To access SM-Applications parameter Pr **71.08** (_Q08%) in the Unidrive SP lowest numerical slot (slot 1) the IDN is "IDN 47108".
- To access SM-Applications parameter Pr **131.08** (_Q08%) in the Unidrive SP slot 2 the IDN is "IDN 53108".
- To access SM-Applications parameter Pr **101.08** (_Q08%) in the Unidrive SP slot 1 the IDN is "IDN 50108".

8 Control and Status Words

8.1 What are control and status words?

The drive control and status words allow the digital control and monitoring of the drive to be implemented using a single data word for each function. Each bit in the control word has a particular function and provides a method of controlling the output functions of the drive, such as run and direction.

Each bit in the status word provides feedback about the drives state of health and operational condition, such as drive ok, drive at speed etc.

To use SERCOS control and status words always refer to the master device user guide for details as the majority of SERCOS masters will have their own style of control and status words which are internally interpreted to the actual SERCOS control word (MDT Control Word) and the slave axis status word (AT Status Word).

If a master device does not have its own style of control or status word then details of the actual SERCOS MDT control word and AT status word are provided in *section 8.2 MDT Control word* and *section 8.3 AT Status word*.

NOTE The Control and Status words referred to in this section relate to the SERCOS state machine and not Pr 6.42 or Pr 10.40.

8.2 MDT Control word

Every MDT (**Master Data Telegram**) from the SERCOS master contains a control word for each slave. The control word is made up of 16 control bits some of which are reserved. See Table 8.1 for the individual bit function descriptions.

Table 8.1 MDT Control word bit definitions

b15	b14	b13	b12	b11	b10	b9	b8
Drive ON / OFF	Enable Drive	Halt / Restart		Operation Mode	IPOSYNC	Operation Mode	
b7	b6	b5	b4	b3	b2	b1	b0
Real-time control bit 2	Real-time control bit 1	Data block element			Last Transmit	Read / Write	MHS

For safety reasons, the external HARDWARE ENABLE (Unidrive SP) / SAFE TORQUE OFF (Digitax ST) signal must be present before the SERCOS control word can be used to start the drive. This terminal is normally controlled by an external “Emergency Stop” circuit to ensure that the drive is disabled in an emergency situation.

Table 8.2 lists in detail the function of each control word bit.

NOTE When a trip occurs, the MDT control word **MUST** be set to a safe, disabled state. This ensures that the drive does not re-start unexpectedly when it is reset. This can be achieved by continuously monitoring the slave AT status word, and interlocking it with the MDT control word.

The drive control word must be enabled (Pr **6.43** = ‘ON’) to allow the MDT control word to control the drive.

Table 8.2 MDT control word bit functions

Bit	Function	Description
0	MHS	0/1 = Service transport handshake of the master.
1	Read / Write	0 = Read Service INFO 1 = Write Service INFO
2	Last transmission	Status of the service channel 0 = Transmission in progress 1 = Last Transmission
3	Data block element	Specifies which data block of an IDN is to be accessed by the service channel.
4		
5		
6	Real time Control Bit 1	Destination specified by IDN 00301.
7	Real time Control Bit 2	Destination specified by IDN 00303.
8	Operation Mode	000 ₂ = Primary operation mode (IDN 00032)
9		001 ₂ = Secondary operation mode 1 (IDN 00033)
10	IPOSYNC	IPOSYNC - the state of this bit is toggled every control unit cycle time. It is used to indicate the availability of either a new position, velocity or torque command.
11	Operation Mode	Used in conjunction with Bits 8 and 9. See bits 8 and 9 for full description.
12	Reserved	
13	Halt / Restart	Specifies which state the drive is in when the Drive ON bit is set. 0 =Halt Drive - Drive Stop state 1 = Restart Drive - Drive Run state
14	Enable Drive	0 = Drive Inhibited. Bits 15 and 13 will be ignored. 1 = Drive Enabled.
15	Drive ON / OFF	0 = Drive OFF - The drive will stop, after a period specified by IDN 00207 it will be switched to the drive ready state. 1 = Drive ON - The drive will be placed in the stop state. The module will wait for the period specified by IDN 00206, and then it will place the drive in the state specified by the Halt/Restart drive bit.

NOTE Although the MDT control word provides the ability to start and stop the drive, the actual method of stopping is controlled by Pr **6.01** (*Stop mode*), see the relevant drive user guide for more details.

8.3

AT Status word

The SM-SERCOS AT (Amplifier Telegram) status word consists of 16 control bits, some of which are reserved. See the following table for the individual bit function descriptions.

b15	b14	b13	b12	b11	b10	b9	b8
Ready to operate		Drive shut-down	Class 2 Diagnostic	Class 3 Diagnostic	Actual operation mode		

b7	b6	b5	b4	b3	b2	b1	b0
Real-time status Bit2	Real-time status Bit1	Procedure command changed		Status command	Service channel error	Busy	AHS

Table 8.3 AT status word bit definitions

Bit	Function	Description
0	AHS	Service channel handshake of the drive
1	Busy	Status of the service channel 0 = step finished, ready for new one 1 = step in progress
2	Service channel error	0 = No error 1 = Service channel error, error message in drive service INFO
3	Status command	Status command value processing 0 = Drive ignores the command values 1 = Drive follows the command values
4	Reserved	
5	Procedure command changed	Procedure command change bit 0 = No change in procedure command acknowledgement 1 = Changing procedure command acknowledgement
6	Real-time status Bit 1	Real time status bit 1 (source specified by IDN 00305).
7	Real-time status Bit 2	Real time status bit 2 (source specified by IDN 00307)
8	Actual operation mode	Actual operation mode 000 ₂ = Primary operation mode (IDN 00032). 001 ₂ = Secondary operation mode 1 (IDN 00033).
9		
10		
11	Class 3 Diagnostics	Class 3 Diagnostics has changed 0 = No change has occurred 1 = A change has occurred
12	Class 2 Diagnostics	Class 2 Diagnostics has changed 0 = No change has occurred 1 = A change has occurred
13	Drive shut-down	Drive shut-down error in IDN 00011 - Class 1 diagnostics 0 = No shut-down 1 = The drive is shut-down due to an error (Trip)
14	Ready to operate	These bits will be determined from the actual drive status, as detailed below. 00 ₂ = The base state at power on. The drive initialised flag is not set. 01 ₂ = This will be set when only the drive initialised flag is set and the drive is inhibited - i.e. the Drive State area of the DPRAM contains code 0. 10 ₂ = This will be set when the drive initialised flag is set and the drive is enabled (In the Ready state) - i.e. the Drive State area of the DPRAM contains code 1. 11 ₂ = This will be set when the drive initialised flag is set, the drive is enabled and the Run or Stop states are set - i.e. the Drive State area of the DPRAM contains code 4 or 2.
15		

9 Procedure Commands

9.1 What are procedure commands?

A procedure command is a non-cyclic data item that is used to start some functional process in the drive. All of the procedure commands that are supported by the SM-SERCOS module are described below.

NOTE All SM-SERCOS procedure commands once enabled are latched and remain latched even after the procedure has completed. Therefore it is necessary for the master to clear the relevant procedure command enable bit(s) to cancel the procedure.

9.2 Homing procedure commands

9.2.1 Homing overview

The purpose of the homing procedure is to calculate and set (calibrate) the position feedback value with respect to the machine axis zero point.

9.2.2 The drive controlled homing procedure command

This method of homing utilises the drive position feedback and requires a home input signal to be directly connected to the drive or master.

To utilise this homing function the associated configuration IDNs and parameters listed below must be set as required.

- Homing velocity (see section 6.3.32 *IDN - 00041* on page 44).
- Homing acceleration (see section 6.3.33 *IDN - 00042* on page 44).
- Reference distance 1 (see section 6.3.40 *IDN - 00052* on page 46).
- Homing parameter (see section 6.3.86 *IDN - 00147* on page 58).
- Reference offset (see section 6.3.88 *IDN - 00150* on page 59).
- Displacement to the referenced system (see section 6.3.96 *IDN - 00172* on page 60).
- Homing switch (see section 6.3.122 *IDN - 00400* on page 68).
- Reverse direction on home switch (see *Pr MM.39* on page 24)
- Homing switch digital input source (see *Pr MM.41* on page 25).
- Marker pulse input source (see *Pr MM.34* on page 91). If this is set you will also need to check *Pr MM.36* (see *Pr MM.36* on page 92) & *Pr MM.37* (see *Pr MM.37* on page 92) if drive feedback is used.
- The homing backoff behavior (*Pr MM.15*).

The homing sequence operates as follows:-

1. The drive homing routine is enabled and armed by setting the SERCOS masters procedure command function.
2. The drive then accelerates the motor up to the homing velocity value set in IDN 00041.
3. SM-SERCOS continuously monitors the home switch status (IDN 0400) for a valid signal. When such a signal is detected the SM-SERCOS waits until the next feedback device marker pulse, upon which it will save the current position value as its reference marker pulse and decelerate the motor to a stop. If the home signal is active at the start of the homing procedure then the homing backoff behavior parameter (Pr **MM.15**) will determine the operation of the axis (see section 11.7 *SM-SERCOS homing backoff behavior* on page 89).
4. Using the values set in IDN 00052, IDN 00150 and marker position the SM-SERCOS calculates the actual machine axis position with respect to the machine axis 0 position.

i.e. IDN 00052 - IDN 00150

5. IDN 00403 status bit is set after the drive controlled homing procedure has completed successfully, and indicates that the position feedback is relative to the machine zero point, i.e. the position feedback IDN 00051 is set to this new value.
6. Once the new machine axis position feedback value has been acquired the drive controlled homing procedure will have to be cancelled before normal slave axis operation can continue.

NOTE Setting Pr **MM.34** allows a freeze input to be used instead of a feedback device marker pulse.

NOTE The second encoder feedback should not be left enabled (Pr **MM.10**) during execution of the homing command. As this may cause a timer task overrun (trip 54).

Figure 9-1 Homing sequence

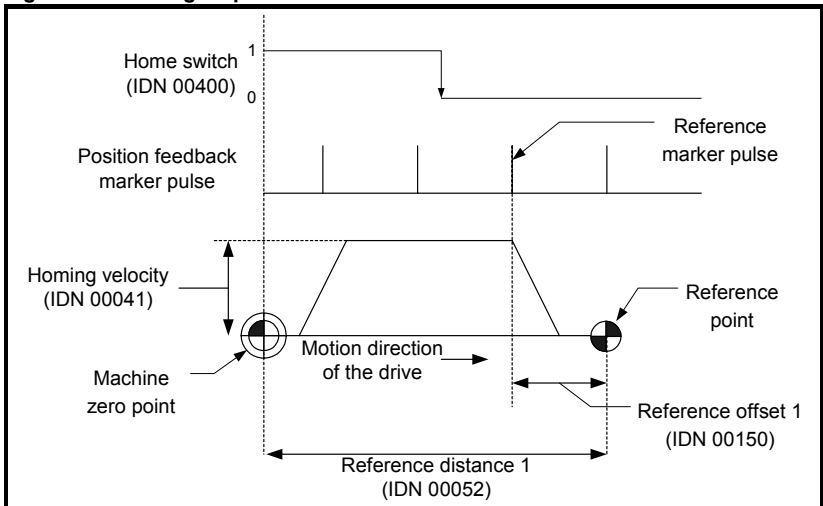

NOTE The SM-SERCOS will ignore position, velocity and torque demands while operating the home procedure.

NOTE

Pr **MM.15** (see section 11.7 *SM-SERCOS homing backoff behavior* on page 89) allows for the situation where the home switch is active at the start of the homing procedure. In this case the drive will reverse (at homing speed) until the home switch is no longer active then continue with a standard homing routine.

9.3 Displacement to the referenced system procedure command

This procedure command is operated by setting IDN 00172. When used the displacement specified in IDN 00175 will be added to the position feedback and IDN 00403 will be set to a value of 1. The procedure command will finish when IDN 00404 is given a value of 1 by the controller / SERCOS master.

9.4 Cancel reference point procedure command

This procedure command is operated by setting IDN 00191. It is used to clear the position feedback value status (IDN 00403) and reset the position feedback offset to zero. Once the reference point has been cleared the procedure will have to be cancelled before the homing procedure can be used again.

9.5 Measurements

9.5.1 Probe cycle overview

The probing (capture) cycle utilises the drive position feedback and requires one or two input signals to be directly connected to SM-SERCOS.

The SM-SERCOS has two fast 24V digital probe inputs. One or both of these inputs can be used to capture and store position data on both a positive and/or negative signal edges.

The probing cycle provides a method of capturing motor shaft position data whenever a SM-SERCOS probe input is triggered.

Cable connections to the probe inputs can be up to 30m in length. Cable lengths longer than this are not recommended, to avoid EMC issues.

9.5.2 The probing cycle procedure command

To utilise this function the associated configuration IDNs listed below must be set as required:-

- Probe control parameter (IDN 00169).
- Probing cycle procedure command (IDN 00170).
- Probe 1 enable (IDN 00405).
- Probe 2 enable (IDN 00406).

The probing cycle sequence operate as follows:-

1. The probing cycle routine is enabled and armed by setting IDN 00170.
2. When a probe input detects a signal edge (as defined in IDN 00169) the appropriate status bits in IDN 00179 (and IDNs 00409 to 00412 which can be used as source data for AT real time status bits) are set. At the same time SM-SERCOS logs the time since the last drive position update (updates occur every 250µs) and uses interpolation to calculate the position for the time logged (this assumes a constant velocity between the position update points either side of the time sample).
3. The SM-SERCOS updates the status bits in IDN 00179 every 250µs. When a bit is set, the calculated position is then stored in either IDN 00130 to IDN 00133 as appropriate.

4. To reuse / repeat the procedure the probe enable IDN(s) must be cleared and then re-enabled by the master.

Digital input 1 can also be used as freeze input, allowing other position feedback modules and the drive position to be frozen, if supported, (see section 11.12 Freeze main drive position on page 92).

NOTE When this procedure command is operating, any changes made to IDN 00169 will not take effect until the appropriate probe enable IDN has seen the required signal edge. The probing cycle command is effected by the second encoder feedback (i.e. if it is enabled (Pr MM.10), the registration position will come from there and not the primary feedback).

9.6 Reset class 1 diagnostic procedure command

This procedure when called by setting IDN 00099 will clear / reset the following status:

- Class 1 diagnostic (IDN 00011).
- Interface error (IDN 00014).
- Manufacturers class 1 diagnostic (IDN 00192).
- Drive shut down bit (AT status word bit 13).
- Attempt to clear the drive trip.

However, this will only be possible if there is no active trip condition currently set in the drive (and no other error condition that would cause bits to be set in the mentioned IDNs).

9.7 CP3 and CP4 transition check procedure commands

These procedure commands (IDNs 00127 and 00128) are initiated by the master at the end of CP2 and CP3, before entering CP3 and CP4 respectively. This is to check that the communications phase has been completed, and that all of the necessary IDN data for the phase has been set.

The CP4 transition check will also ensure that the SM-SERCOS is operating correctly as the synchronisation master for the drive and any other Solutions Modules that are linked to the synchronisation signal. If the SM-SERCOS is not the synchronisation signal producer (or if the synchronisation signal it is providing is not within specification), the CP4 transition check will fail.

Safety Information
Introduction
Mechanical Installation
Electrical Installation
Getting started
IDNs
Manufacture IDNs
Control and Status Words
Procedure Commands
Data Synchronisation
Advanced Features
Diagnostics
Quick reference
Glossary Of Terms
Index

10 Data Synchronisation

10.1 Synchronisation

10.1.1 Overview

Synchronised position control allows a group of axes on a SERCOS network to make their programmed position moves at the same time. This is very important in precision CNC machines, as the level of synchronisation between axes partly determines the “smoothness” of motion when following a curved profile.

The drive will allow one of the installed option modules to adjust the timing of the internal loops to keep it synchronised to an external signal. The solutions module responsible for this is known as the “synchronisation producer”.

Synchronisation over SERCOS is a method of operation where the SM-SERCOS synchronises the drive control loops with the cycle time of the SERCOS network. This ensures that the drive speed loops are synchronised across the SERCOS network, and will use their new data references at the same time.

If the SM-SERCOS is unable to become the synchronisation producer, it will not be possible to advance to CP4. This might occur, for example, if another module in a lower option slot is the synchronisation producer. In this case, the CP4 transition check (see *IDN - 00128* on page 55) will fail. Also during CP4 the synchronisation status is checked periodically. If the producer status is lost (e.g. if a module in lower option slot becomes the synchronisation producer), or if the drive detects that the synchronisation waveform being provided from the SERCOS network is not within the proper specification, the SM-SERCOS will signal an error and return to CP0.

When a SM-Applications module is installed it is possible to make the POS tasks also synchronise to the SERCOS network master. See *SM-Application User Guide* for details on how to make it operate as a synchronisation consumer when using inter-option synchronisation.

NOTE

Unidrive SP must have firmware V01.06.00 or later to support inter-option synchronisation. Any SM-Applications modules installed must have V1.03.00 or later system file installed to support inter-option module synchronisation. Cyclic transfer of data is supported using the cyclic data transfer method as described in section 11.18 *Cyclic access to SM-Applications* on page 94

10.1.2 Synchronisation modes

SM-SERCOS will automatically configure itself as the synchronisation producer for its drive, however, if 2 or more option modules are configured to be the synchronisation producer for the drive, the module installed in the lowest numerical slot will be the synchronisation producer.

When SM-SERCOS is enabled as the synchronisation producer, it will use the SERCOS MST message as the external synchronisation signal.

NOTE

Only one SM-SERCOS should be installed on a drive. If more than one SM-SERCOS module is installed only the SM-SERCOS in the lowest numerical slot will be functional.

10.2 Synchronisation status

SM-SERCOS Synchronisation status		
Pr MM.44	Default	
	Range	0 to 7
	Access	RO

Synchronisation status indicates the current synchronisation state of the SM-SERCOS. Pr **MM.44** is only updated when the SM-SERCOS has been enabled as the synchronisation producer (see *Synchronisation modes* on page 80).

Table 10.1 Synchronisation status

Bit	Function	Description
0 to 1	SYNC MODE	Indicates the requested synchronisation mode 0 = The module is independent. 1 = The module is the synchronisation producer.
2	PRODUCER ACTIVE	This bit indicates that the SM-SERCOS has successfully become the synchronisation producer.
3	SYNC OK	Indicates that the jitter in the external signal being used to generate the DINT message is within tolerance.
4 to 7	Reserved	Reserved.

The timing accuracy of the MST from the SERCOS master controller is very important if the SM-SERCOS is to maintain synchronisation. See *section 10.7 Timing accuracy* on page 85. When using SM-Applications this parameter should be monitored to ensure reliable operation.

10.3 Synchronisation period

SM-SERCOS Synchronisation period		
Pr MM.45	Default	
	Range	0 to 6
	Access	RO

When the SM-SERCOS has synchronised with the SERCOS network and become the synchronisation producer, Pr **MM.45** indicates the current synchronisation period. If synchronisation is lost for any reason, this value will be reset to 0. When using SM-Applications this parameter should be monitored to ensure reliable operation.

Table 10.2 Synchronisation period

Value	Period
0	Not synchronised
1	250µs
2	500µs
3	1ms
4	2ms
5	4ms
6	8ms

10.4 Internal interrupts

10.4.1 RMINT

RMINT is a hardware interrupt within the drive, and is used to control the execution of the speed loop. It is generated nominally every 250µs, but the internal phase-locked loop may be adjusted to synchronise to an external signal (see section 10.7 Timing accuracy).

Synchronisation between a SERCOS master and a drive is achieved by specifying SM-SERCOS as the “synchronisation producer”. It is also possible to set a SM-Applications as “synchronisation consumer”; SM-Applications will synchronise to the same RMINT as SM-SERCOS and synchronisation between the modules is guaranteed. For more information on synchronous transfer of data (see section 11.18 *Cyclic access to SM-Applications* on page 94).

10.4.2 DINT

DINT is generated by the SM-SERCOS every 250µs. It is used by the drive to determine the phase-lock loop adjustment required, and this adjustment is applied when the next RMINT occurs. Any change of timing in RMINT will be seen on the 2nd RMINT after DINT occurred.

10.5 Position control without interpolation

Position reference interpolation is not required if the SERCOS master and network cycle times (see section 10.3 *Synchronisation period*) are the same as the drive speed loop cycle time (250µs). The new position reference received from the SERCOS master controller can be processed in the SM-SERCOS position controller on each cycle.

Figure 10-1 shows a synchronised SERCOS system consisting of 4 nodes running at 250µs SYNC time.

Figure 10-1 Position control without interpolation

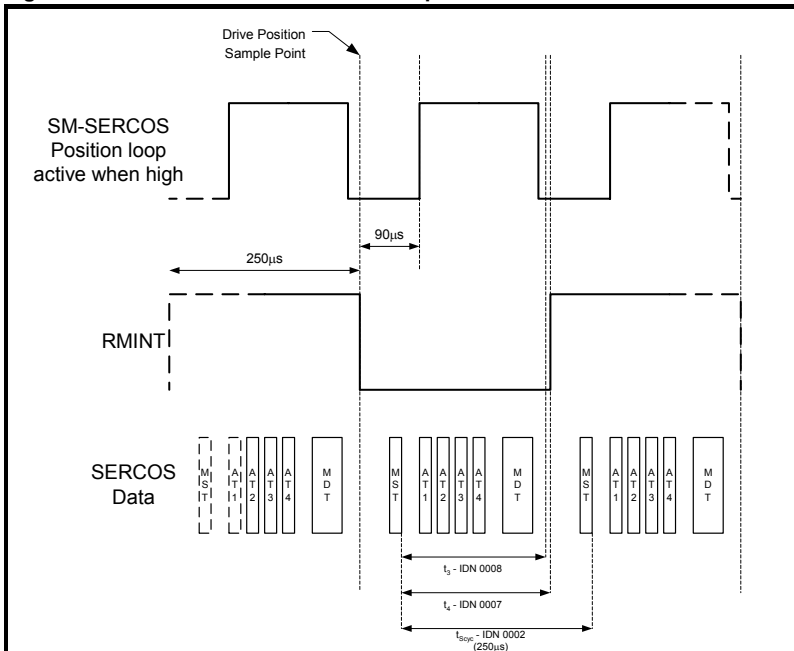
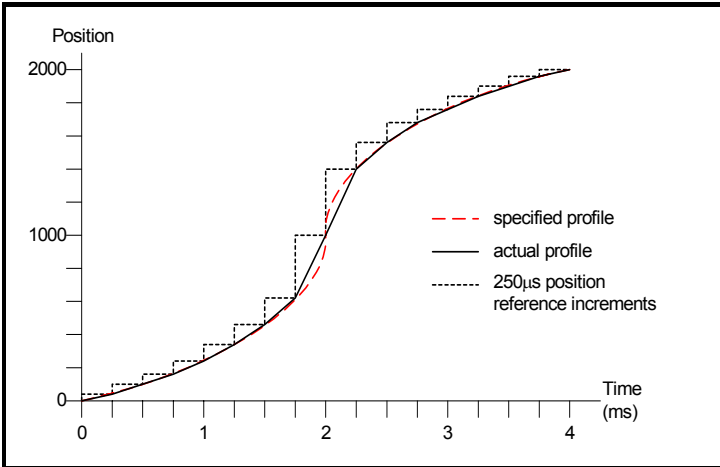

Figure 10-2 Example profile 1



10.6 Position control with interpolation

Position reference interpolation is required if the SERCOS master and network cycle times (see section 10.3 Synchronisation period) are different to the drive speed loop cycle time (250µs).

Figure 10-3 Position control with interpolation

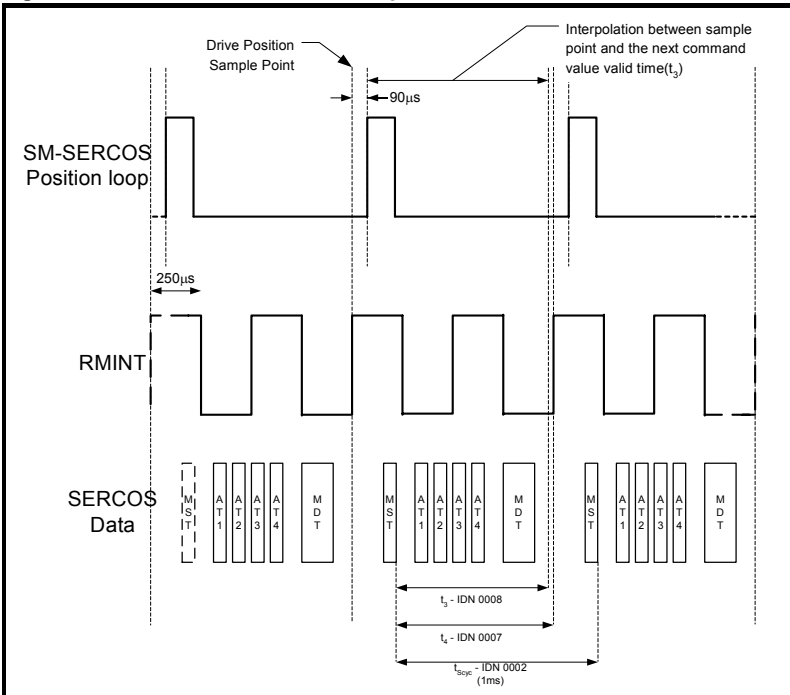

When the SERCOS master cycle time is 1ms, the position reference received from the master controller is the target position that must be achieved 1ms later. If the SM-SERCOS position controller is running every 250µs, it will try to move to the new position in 250µs, instead of 1ms. The actual movement that will be produced is shown in Figure 10-4, and looks nothing like the specified profile.

Figure 10-4 Uninterpolated position profile

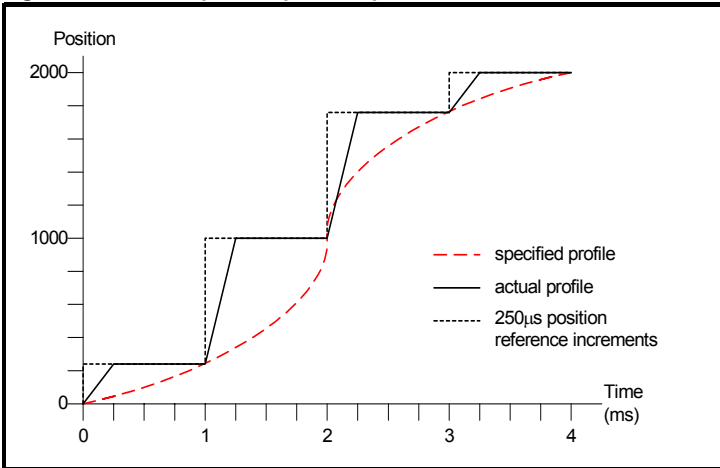

The solution is to use position reference interpolation. When a new position reference is received from the SERCOS master controller, 4 intermediate step positions can be calculated and passed to the position controller on each 250µs cycle. This is shown in Figure 10-5 using linear interpolation, where each interpolated position reference is a quarter of the position move required during the 1ms period.

Figure 10-5 Profile with interpolation

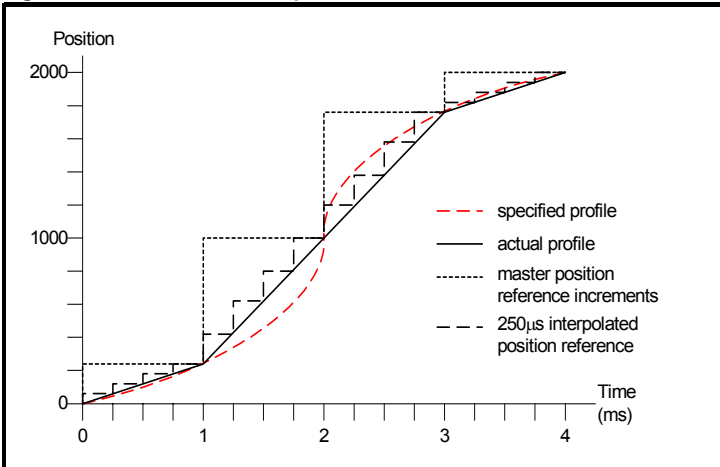

10.7 Timing accuracy

Table 10.3 shows the timing specifications for a synchronised SERCOS network.

Table 10.3 Synchronised SERCOS specifications

Function	Range	Description
Master SYNC accuracy	$\pm 0.4\%$	The maximum range in the nominal MST time produced by the SERCOS master for SM-SERCOS to maintain synchronisation.
Master SYNC jitter	1 μ s max	The maximum permitted jitter in the MST message for SM-SERCOS to maintain synchronisation.
Slave RMINT jitter	$\pm 2\mu$ s	The maximum jitter in the RMINT interrupts between any 2 drives synchronised using SM-SERCOS

NOTE Excessive jitter on the network will produce errors.

10.7.1 MST absolute timing accuracy

The drive phase-locked loop generates RMINT nominally every 250 μ s, but this can be adjusted by $\pm 1\mu$ s to compensate for small differences in crystal clock frequencies between different devices. RMINT cannot be adjusted outside of this limit, so this gives a maximum adjustment of 1 μ s for every 250 μ s, i.e. 0.4%. The SERCOS master must be able to produce the MST message nominally every 250 μ s, 500 μ s or from 1ms up to 65ms in 1ms increments, with an accuracy of $\pm 0.4\%$.

If the SERCOS master is configured to produce the MST message every 250 μ s, but it actually produces it every 250.5 μ s, this equates to an error of 0.2% so it will not cause a problem. SM-SERCOS will synchronise to the SYNC message and adjust the timing of the drive phase-locked loop to generate RMINT every 250.5 μ s. The 250 μ s position loop in SM-SERCOS and ρ os tasks in SM-Applications will now run every 250.5 μ s, and remain fully synchronised with the SERCOS master.

10.7.2 SYNC jitter

SYNC jitter is the continuous variation in the actual timing between MST messages. SM-SERCOS can handle SYNC jitter of $\pm 1\mu$ s without losing synchronisation.

If the SERCOS master is producing the MST message nominally every 250.5 μ s with 1 μ s jitter, the timing between MST message will range from 249.5 μ s to 251.5 μ s. However, over a period of time, jitter will typically cancel out, and the average MST message time seen by SM-SERCOS will be 250.5 μ s.

If the SM-SERCOS detects two or more consecutive master MST messages that exceed 1 μ s jitter then the SM-SERCOS will indicate an error by setting the MST error bit 3 in IDN 00014 and communication error bit 12 of IDN 00011.

NOTE The drive cannot compensate for severe problems with master synchronisation signals. It is ultimately the master's responsibility to ensure that the MST is accurately generated in order to ensure good motion.

Safety Information
Introduction
Mechanical Installation
Electrical Installation
Getting started
IDNs
Manufacture IDNs
Control and Status Words
Procedure Commands
Data Synchronisation
Advanced Features
Diagnostics
Quick reference
Glossary/Of Terms
Index

10.7.3 Slave RMINT accuracy

The accuracy of the synchronisation process using SM-SERCOS is quoted as the maximum jitter that will be seen between the RMINT signals of any 2 drives on the SERCOS network.

$$\text{Maximum RMINT jitter} = \pm 2.0\mu\text{s}$$

As the drive speed loop runs every $250\mu\text{s}$, the maximum synchronisation jitter BETWEEN ANY 2 DRIVES equates to 0.8% across the SERCOS network. Figure 10-6 shows how the timings of RMINT may vary between 4 drives across a network, but the difference between any 2 RMINT signals will not exceed $\pm 2\mu\text{s}$.

Figure 10-6 Jitter on RMINT

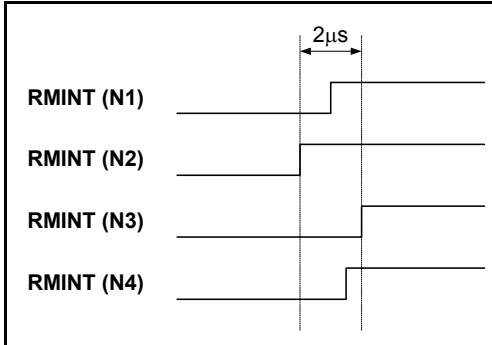

In this case, the worst case delay between RMINTs is between node 2 and node 3. The difference between any other pair of nodes is always less than $2\mu\text{s}$.

11 Advanced Features

11.1 SM-SERCOS network loss trip

SM-SERCOS network loss trip enable		
Pr MM.07	Default	0
	Range	0 to 1
	Access	RW

Enabling the network loss trip provides a method of tripping and therefore disabling the drive, if an error occurs that causes SM-SERCOS operating status (Pr MM.06) to return to CP0 such as an optical fiber fault or excessive distortion.

When SM-SERCOS forces the trip, the trip displayed on the drive will be “SLx.Er”, where “x” is the slot number where the trip originated. The SM-SERCOS error code parameter (Pr MM.50) will show 65 when a network loss trip has occurred.

NOTE Any return to CP0 will cause this trip. When the network loss trip is disabled by setting Pr MM.07 to 0, the SM-SERCOS will still disable the drive but will not trip it.

11.2 SM-SERCOS data endian format

11.2.1 What does endian format mean?

When data is sent over a network it is transmitted as 8-bit bytes. Therefore when a 16-bit word or 32-bit word is transmitted it is split into two or four 8-bit bytes. It is important that the receiving node reconstructs the received 8-bit bytes in the correct order to arrive at the 16-bit or 32-bit data value that was originally transmitted, this order is known as the “Data Endian Format”.

Data endian format	Pr MM.08	16-bit value	32-bit value	
		Byte order	Word order	Byte order
Big	OFF	High byte first Low byte second	High word first Low word second	High byte first Mid high byte second Mid low byte third Low byte fourth
Little	ON	Low byte first High byte second	Low word first High word second	Low byte first Mid low byte second Mid high byte third High byte fourth

11.2.2 SERCOS endian format

This read only parameter displays the endian format of the SM-SERCOS module. The SM-SERCOS uses little endian format as should all SERCOS conformant devices.

SM-SERCOS data endian format		
Pr MM.08	Default	ON
	Range	OFF (0) or ON (1)
	Access	RO

11.3 SM-SERCOS register control

This read only parameter displays the register mode of the 'I' and 'O' registers (Pr **MM.10** to Pr **MM.29**). The value of 1 (ON) signifies the 'I' and 'O' registers are to store data directly (they are not parameter mappings). This parameter cannot be changed on SM-SERCOS.

SM-SERCOS register control		
Pr MM.09	Default	ON
	Range	OFF (0) or ON (1)
	Access	RO

11.4 SM-SERCOS second encoder enable

Specifies if the position value in the second encoder is to be made available in IDN 00053. A value of 0 signifies that the value should not be made available. This parameter will take effect immediately (it is not necessary to reset the option module). When this value changes from 0 to 1, parameters Pr **MM.11** and Pr **MM.12** will configure the feedback. When this facility is disabled, IDN 00053 will be assigned a value of 0. The second encoder cannot be used by the APC in SM-SERCOS and is intended for use in one and a half axis machines.

SM-SERCOS second encoder enable		
Pr MM.10	Default	ON
	Range	OFF (0) or ON (1)
	Access	RW

NOTE The second encoder feedback should not be left enabled during execution of the homing command. As this may cause a timer task overrun (trip 54).

11.5 SM-SERCOS second encoder source

Specifies where the second position feedback device is connected. This encoder cannot be used for on-board control (SM-SERCOS APC), but can be sent over the network cyclically or read by the master non-cyclically, using IDN 00053.

SM-SERCOS second encoder source		
Pr MM.11	Default	0
	Range	0 to 3
	Access	RW

The value in Pr **MM.11** will determine the second encoder feedback source.

Pr MM.11	second encoder source
0	Drive encoder feedback.
1	Encoder feedback from slot 1
2	Encoder feedback from slot 2.
3	Encoder feedback from slot 3.

NOTE This parameter requires a 0 to 1 transition of Pr **MM.10** to implement any changes.

11.6 SM-SERCOS second encoder turn bits

Specifies the number of bits of the external encoder revolution count that will be right-shifted into SERCOS second encoder feedback values. A corresponding number of fine position bits will be right-shifted out of the position parameter.

SM-SERCOS second encoder turn bits		
Pr MM.12	Default	16
	Range	1 to 16
	Access	RW

NOTE This parameter requires a 0 to 1 transition of Pr **MM.10** to implement any changes.

11.7 SM-SERCOS homing backoff behavior

SM-SERCOS homing backoff behavior		
Pr MM.15	Default	0
	Range	0 to 2
	Access	RW

This parameter defines the behavior of the homing routine in the event that the home switch is active at the start of the homing procedure. This is important if the home switch could be active for multiple marker pulses.

Pr MM.15	homing backoff behavior
0	The backoff direction is the opposite of the selected homing direction (see IDN 00147). This is the default operation.
1	The backoff direction is the same as the selected homing direction (see IDN 00147).
2	No backing off will occur.

If the homing input is active when homing starts, this parameter defines the method of backoff that will occur in order to deactivate the homing input before homing is started.

11.8 Restore SM-SERCOS defaults

Restore SM-SERCOS defaults		
Pr MM.30	Default	OFF (0)
	Range	OFF (0) or ON (1)
	Access	RW

If the host drive is defaulted (see the drive user guide for details) it will also clear the current configuration for the slot SM-SERCOS is installed to. Setting Pr **MM.30** to 1 additionally clears the backup copy of the SM-SERCOS configuration stored in the SM-SERCOS (see Section 11.9 for more details).

The sequence is as follows:

- Set Pr **MM.30** to 1.
- Set Pr **MM.00** to 1233 to restore European defaults (1244 for USA defaults).
- SERCOS communications will be stopped.
- The host drive will load and store its default parameter values.
- Default parameter values for the SM-SERCOS will be loaded in Pr **MM.XX** parameters.

- SM-SERCOS default parameter values will be stored in the backup copy in SM-SERCOS FLASH memory.
- The SM-SERCOS will reset and re-initialise using the default values.

11.9 Storing SM-SERCOS parameters (backup)

Store to SM-SERCOS FLASH memory		
Pr MM.31	Default	OFF
	Range	OFF (0) to ON (1)
	Access	RW

Option slot parameters are stored in the host drive memory and SM-SERCOS will always use these values during initialisation to configure itself. If a new SM-SERCOS is installed to the same slot it will communicate using the same settings as the previous SM-SERCOS.

Using Pr **MM.31** it is possible to store the configuration as a backup copy in the SM-SERCOS module. This allows the module to contain a backup copy of its configuration that may be restored using Pr **MM.33** (see section 11.10). This is of particular use when setting up a module to send to site as a replacement or as a method of keeping a backup copy of the SM-SERCOS settings that may be used in the event of a drive failure.

NOTE If the stored values in the drive are for a different type of Solutions Module, the drive will trip with a slot error. The slot configuration parameters will be set to default values for SM-SERCOS, but the default values will NOT be stored in the drive.

To store SM-SERCOS parameters in the SM-SERCOS FLASH backup copy:

- Set Pr **MM.31** to 1.
- Set Pr **MM.00** to 1000.
- Press the red RESET button.

The drive will perform a drive save and additionally copy the settings from the slot menu associated with the SM-SERCOS and copy them in the SM-SERCOS local FLASH memory.

NOTE Drive parameters are NOT stored in SM-SERCOS.

11.10 Restore previous SM-SERCOS configuration

Restore previous SM-SERCOS configuration		
Pr MM.33	Default	OFF (0)
	Range	OFF (0) or ON (1)
	Access	RW

If valid configuration parameters have previously been stored in the SM-SERCOS FLASH memory these values can be restored to the host settings for SM-SERCOS. When the configuration parameter values have been uploaded to the host drive the SM-SERCOS will reset and re-configure using the updated parameter values. This feature allows a pre-configured SM-SERCOS to be installed to a host drive without losing the SM-SERCOS configuration.

NOTE If the SM-SERCOS is unable to upload the configuration parameters to the host drive or configuration parameters have never been stored in the SM-SERCOS FLASH memory the drive will trip with a slot error and set the error code (Pr **MM.49**) to 70.

When Pr **MM.33** is set to ON the SM-SERCOS will transfer the configuration parameters from its FLASH memory to the host drive over-writing the existing values in the host drive.

The full sequence of events for restoring values from a SM-SERCOS installed in slot **MM** is as follows:

- Set Pr **MM.33** to ON.
- SERCOS communications will be stopped.
- The SM-SERCOS will overwrite all Pr **MM.XX** parameters with the values stored in its internal FLASH memory.
- Pr **MM.33** will be reset to OFF.
- The SM-SERCOS will reset and re-initialise using the restored values.

NOTE This procedure will **NOT** store the updated host drive parameters and a drive save will be required to update the drive memory. Failure to do this will result in SM-SERCOS resorting to previously stored parameters in the drive FLASH following a power down.

NOTE SM-SERCOS will restore its configuration parameters to the menu of parameters associated with the slot that it is installed in. If SM-SERCOS is moved from a slot on a drive it can be re-installed in any slot on another drive and will pass its configuration to the drive.

NOTE The SM-SERCOS store and upload parameters should not be used while the SERCOS network is operational.

11.11 Marker pulse source

SM-SERCOS freeze main drive position		
Pr MM.34	Default	OFF (0)
	Range	OFF(0) to ON (1)
	Access	RW

Normally the drive controlled homing procedure command requires a marker pulse to home the axis to. However, some motor position feedback devices do not produce a marker pulse, therefore this parameter, when set, allows the freeze input from the currently selected feedback source (see section 5.4.7 *Position feedback source* on page 25) to be used instead of the marker pulse see section 11.12 *Freeze main drive position for details on freeze input source*.

NOTE The homing procedure command will function as normal even when using a freeze input as the marker pulse source.

11.12 Freeze main drive position

SM-SERCOS freeze main drive position		
Pr MM.36	Default	OFF (0)
	Range	OFF(0) to ON (1)
	Access	RW

SM-SERCOS Invert drive freeze		
Pr MM.37	Default	OFF (0)
	Range	OFF(0) to ON (1)
	Access	RW

When parameter Pr **MM.36** is set to ON, the freeze 1 input (pin 2 on the digital input connector) will be routed onto the main drive freeze line in addition to the module freeze. When a freeze occurs, the position can be determined by reading the appropriate drive parameters.

If the parameter Pr **MM.37** is set to ON, the freeze 1 input will be inverted before it is routed onto the main drive freeze.

11.13 Test mode

SM-SERCOS test mode		
Pr MM.38	Default	0
	Range	0 to 2
	Access	RW

This parameter is used to enable either the zero bit stream or continuous light test modes. These test modes are particularly useful during commissioning and when diagnosing network problems.

The zero bit stream test mode will generate a square wave output, with a frequency that is half of the SERCOS data rate. For example, a 16Mbps zero bit stream will give an 8MHz square wave. This is based on the NRZI encoding used by SERCOS networks. The continuous light test mode uses a test signal of a continuous stream of high bits.

NOTE When one of the test modes is selected, Pr **MM.06** will display a value of -1 (no network present).

11.14 Disable SM-SERCOS control

SM-SERCOS disable SM-SERCOS control		
Pr MM.40	Default	0
	Range	0 to 1
	Access	RW

This parameter is provided to prevent the SM-SERCOS module from controlling the drive control parameters directly. This is particularly useful when an SM-Applications module is required to have control of the drive based on references supplied over SERCOS. A value of 1 in this parameter will prevent SM-SERCOS from directly controlling the drive.

NOTE SM-SERCOS will still provide a synchronisation signal to the drive and option modules, regardless of this parameters setting.

11.15 Menu 61 - SM-SERCOS virtual parameters

Menu 61 allows a SERCOS master to adjust parameters on a SM-SERCOS module independently of the slot number the module is installed to. The required SM-SERCOS node is accessed using its SERCOS address in conjunction with menu 61.

To change a parameter on SM-SERCOS a non-cyclic message should be sent to the node using menu 61 as the destination.

Table 11.1 Local slot configuration parameter access

Parameter	SM-SERCOS in slot 1	SM-SERCOS in slot 2	SM-SERCOS in slot 3
Pr 61.01 - Pr 61.51	Pr 15.01 - Pr 15.51	Pr 16.01 - Pr 16.51	Pr 17.01 - Pr 17.51



Menu 61 parameters are only accessible from the SERCOS network using the non-cyclic data access method (service channel), for more details see section 11.16.3 *Non-cyclic data* on page 93.

11.16 Cyclic and non-cyclic data communications

11.16.1 Overview

All master to slave cyclic and non-cyclic data transactions are actually contained within the same network MDT messages. Likewise all slave to master cyclic and non-cyclic data are contained within each slaves AT message.

As with the control and status words (which are also contained within the MDTs and ATs see Chapter 8 *Control and Status Words* on page 73) each SERCOS master manufacturer has their own method of implementing control strategies in their PLC / motion controllers, therefore it is beyond the scope of this user guide to document how to construct cyclic and non-cyclic messages on the master, however *section 11.16.2 Cyclic data* and *section 11.16.3 Non-cyclic data* briefly outlines the functions of each message type.

11.16.2 Cyclic data

Cyclic data transfer is a method of transferring data on a regular time period and is often known as “polled data”. SERCOS cyclic data must be pre-configured so that the source and destinations are set just the once. Then data is updated on the defined time period.

Typical SERCOS cyclic data is:-

- The master to drive axis velocity / position / torque references.
- The slave (drive) to master velocity / position / torque feedback values.

11.16.3 Non-cyclic data

In addition to the cyclic transmission of data, the SERCOS interface provides the ability to transmit non-cyclic data. Control and status bits in the MDT control word and the AT status word are used to control execution of the service channel. Therefore, the master is able to support a separate service channel for every connected drive.

Non-cyclic transmissions are used for the following operations:

- Initialisation of the SERCOS interface.
- Transmission of all elements of a data block.
- Transmission of procedure commands.
- Changing limit values on demand.

- Changing control loop parameters on demand.
- Obtaining detailed status messages from a drive.
- Diagnostic functions.

Service channel non-cyclic transmissions are always initiated and controlled by the master.

The service channel is initialised during CP2 and is functional for the remainder of the communication phases.

NOTE For SERCOS the correct name associated with the network non-cyclic data transfer is the "Service Channel".

In addition to dynamically controlling IDNs, if required the service channel can also be used to communicate directly to the drive parameters, (*see section 7 Manufacture IDNs for further details*).

11.17 Telegram type 7

This is the user defined telegram type that allows the user to choose the required cyclic data that is to be transferred between the SERCOS master and slaves.

To utilise this telegram type it has to be selected using IDN 00015. The required IDNs to be transmitted cyclically have to be listed in IDN 00016 (AT) and IDN 00024 (MDT).

When using telegram type 7 only the IDNs listed in IDN 00187 (AT) and IDN 00188 (MDT) can be used for the cyclic data. Attempting to use IDNs that are not listed will result in the SM-SERCOS failing the slave CP3 transition check.

NOTE Telegram type 7 can be configured to send data to and from SM-Applications for use in systems requiring the SM-Applications to have direct control of the drive, see section 11.18 *Cyclic access to SM-Applications* for more information.

11.18 Cyclic access to SM-Applications

A facility is available that allows data to be passed cyclically to and from SM-Applications. This allows a SM-Applications module to receive data from the MDT cyclic channel (through menu 20) and to return data in the AT cyclic channel (through menu 20) to the SERCOS controller.

This requires SM-SERCOS to be synchronised with the SERCOS MST, hence allowing the real time tasks on SM-Applications to be synchronised across multiple SM-Application modules or drives.

11.18.1 SM-SERCOS as a synchronisation producer

SM-SERCOS will automatically act as the synchronisation producer within the drive, the remaining configuration must be done within SM-Applications. Parameters Pr **MM.44** (synchronisation status) and Pr **MM.45** (synchronisation period) should be monitored within DPL to ensure the SM-SERCOS is functioning correctly as a synchronisation producer for the drive.

11.18.2 SM-Applications/SM-Applications Lite as a synchronisation consumer

For SM-Applications/SM-Applications Lite setup details see the combined user guide under the section "Inter-option Synchronisation". The SM-Applications `POS` task interval should be made equal to or less than the SERCOS network cycle time. This also dictates that the SERCOS cycle times should be either 250µs, 500µs, 1ms, 2ms, 4ms or 8ms.

11.18.3 IDNs required for SM-Applications

Data to be transferred cyclically must be achieved using menu 20 as an intermediate step, the list of IDNs used to send data to the master is given in IDN 00187, the specific IDNs for menu 20 AT transfers are listed below. These are the IDNs you should configure in your cyclic data.

- IDN 42001 [P-2-1041] Application Menu 3 read-write integer (Pr **20.01**)
- IDN 42002 [P-2-1042] Application Menu 3 read-write integer (Pr **20.02**)
- IDN 42021 [P-2-1061] Application Menu 3 read-write long integer (Pr **20.21**)
- IDN 42022 [P-2-1062] Application Menu 3 read-write long integer (Pr **20.22**)

The list of IDNs used to receive data from the master is given in IDN 00188, the specific IDNs for menu 20 MDT transfers are listed below. These are the IDNs you should configure in your cyclic data.

- IDN 42003 [P-2-1043] Application Menu 3 read-write integer (Pr **20.03**)
- IDN 42004 [P-2-1044] Application Menu 3 read-write integer (Pr **20.04**)
- IDN 42023 [P-2-1063] Application Menu 3 read-write long integer (Pr **20.23**)
- IDN 42024 [P-2-1064] Application Menu 3 read-write long integer (Pr **20.24**)

11.18.4 Timing constraints

Data transfer to and from SM-Applications will occur in the period immediately before the start of the real time task, and as such will be available without change during the task. This has the effect of introducing a delay between the data arriving in SM-Applications and conversely arriving back in the PLC. This delay will be dependent on the PLCs internal timings, but will be consistent for a specific configuration.

The SM-SERCOS module will write data to and read data from the parameters on every T4 when the IPOSYNC bit has been toggled. The data written will be that cached at the last T3 point.

From the point at which data is received from the master (in the MDT), it will be cached at the following T3 point. This data will then be written in the 90µs period immediately after the next T4 point, if the IPOSYNC bit has been toggled.

Safety Information
Introduction
Mechanical Installation
Electrical Installation
Getting started
IDNs
Manufacture IDNs
Control and Status Words
Procedure Commands
Data Synchronisation
Advanced Features
Diagnostics
Quick reference
Glossary Of Terms
Index

Figure 11-1 SERCOS network timing sequence chart

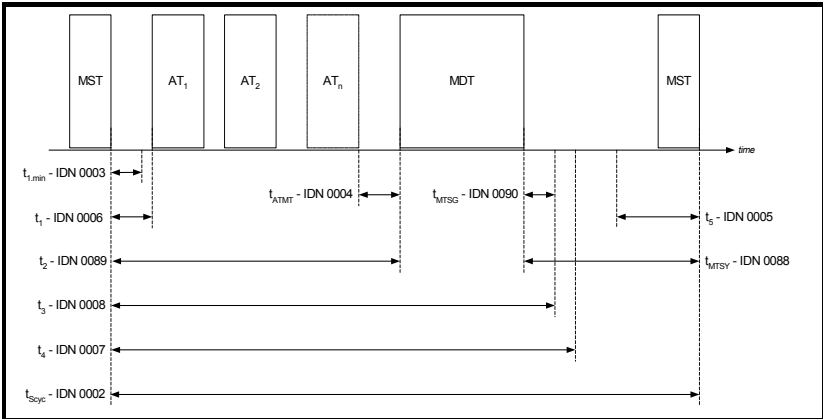

If the SM-Applications is correctly operating as a consumer of the SM-SERCOS synchronisation signal, the SM-Applications `POS` task will begin 90µs after the T4 point (and so the user should include code to use the cyclic data received from the SM-SERCOS module at the start of `POS`).

The SM-SERCOS module will read feedback data from the cyclic parameters every T4, when IPOSYNC has been toggled. This means that the data will be transmitted to the master in the following AT. The user must ensure that the SM-Applications `POS` task code writes the feedback data to the parameters before this point.

NOTE

It should be noted that IPOSYNC bit in the control word, must be toggled, else data mapping will not occur. This should be done in the user PLC code (unless this process is performed automatically by the master). If the network is unstable synchronisation cannot be maintained.

11.19 Always require IPOSYNC bit

Always require the IPOSYNC bit		
Pr MM.16	Default	0
	Range	0 to 1
	Access	RW

Normally, in the case where the controller and network cycle time IDNs have the same value, the module will not require the IPOSYNC bit to be toggled in order to use new command values. However, setting this parameter to 1 will always require the IPOSYNC bit to be toggled at intervals of the controller cycle time, even in the case where the two cycle times have the same value.

11.20 Module timer task period

Module timer task period		
Pr MM.17	Default	0
	Range	1 to 6
	Access	RW

The interval at which the module timer task is run. This also dictates the interval between which the position controller is run, and the interval at which new position commands are generated by the on-board fine interpolator.

Value	Timer task period
1	250µs
2	500µs
3	1ms
4	2ms
5	4ms
6	8ms

12 Diagnostics

This section provides basic diagnostic information intended to enable resolution of the most common problems encountered when setting up a SM-SERCOS on a SERCOS network.

A high percentage of problems reported are basic set-up problems that can be avoided by using the following pages. Start by using the following flow chart to determine the possible cause of a problem. If after following the flow chart you are still experiencing problems please contact your supplier or local Drive Centre for support.

NOTE Please note that support will be limited to the setting up the drive and SM-SERCOS.

Figure 12-1 Diagnostic flow chart

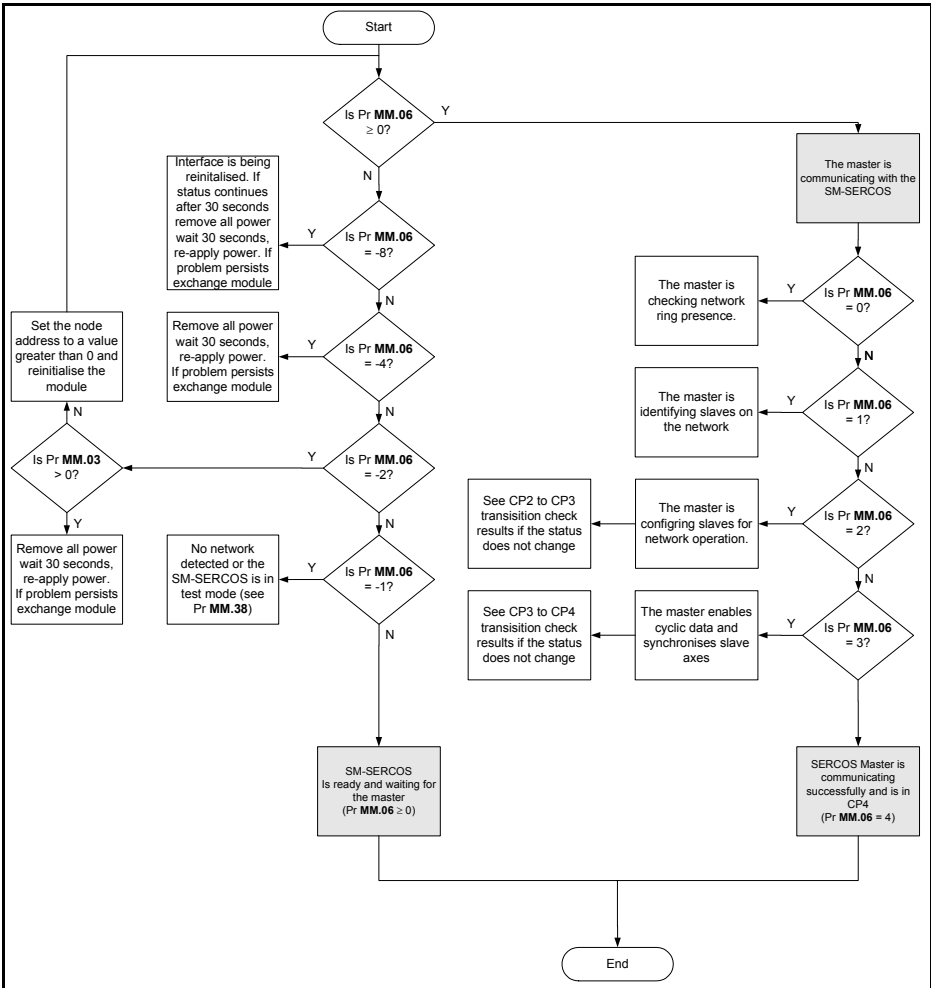

12.1 Module ID code

Module ID code		
Pr MM.01	Default	409 (SM-SERCOS)
	Range	0 to 499
	Access	RO

The module ID code indicates the type of module installed to the slot corresponding to menu **MM**. The module ID code for SM-SERCOS is 409.

12.2 SM-SERCOS firmware version

SM-SERCOS firmware - major version (xx.yy)		
Pr MM.02	Default	
	Range	00.00 to 99.99
	Access	RO

SM-SERCOS firmware - minor version (zz)		
Pr MM.51	Default	
	Range	0 to 99
	Access	RO

The full version of the SM-SERCOS firmware can be read for the module. The full version is assembled by combining the major version (xx.yy) and the minor version (zz) as follows: xx.yy.zz.

12.3 SM-SERCOS node address

SERCOS node address		
Pr MM.03	Default	254
	Range	0 to 254
	Access	RW

Each node on a SERCOS network must be given a unique network node address. The SM-SERCOS must be re-initialised to make a change of node address take effect. Address 0 is used to disable the SM-SERCOS from being an active node, but the network ring will remain functional as the module will behave as a repeater.

12.4 SM-SERCOS data rate

All nodes (master and slaves) on the SERCOS network must be set to use the same network data rate. The SM-SERCOS is set using Pr **MM.04**.

SERCOS data rate		
Pr MM.04	Default	3
	Range	0 to 3
	Access	RW

A value between 0 to 3 may be used. Each value represents a data rate as follows:

Table 12.1 SM-SERCOS data rates

Pr MM.04	bit/s
0	2M
1	4M
2	8M
3	16M

12.5 SM-SERCOS optical transmitter power level

SM-SERCOS transmitter optical power level		
Pr MM.05	Default	4
	Ranges	0 to 4
	Access	RW

This parameter controls the light power level of the optical transmitter. It is provided so that different lengths and types of fiber cable can be used.

A value of zero means that the light is off (which effectively breaks the network ring), and four is the maximum output.

In practice leaving the power level set at the default level is acceptable for the majority of applications, however, if it is necessary to calculate a more accurate match between the fiber cable attenuation and the optical power level see *section 5.4.4 Setting the optical transmitter power level* on page 23.

NOTE

If the optical power level is set too high it is possible to saturate the next node in the SERCOS ring. If in doubt an optical signal strength meter should be used.

12.6 SM-SERCOS operating status

SM-SERCOS operating status		
Pr MM.06	Default	
	Range	-8 to 4
	Access	RO

The operating status of the SM-SERCOS can be viewed in the operating status parameter (Pr **MM.06**). When the SM-SERCOS is communicating successfully with the SERCOS master controller, Pr **MM.06** will indicate the communication phase number. If there is a network or module error then Pr **MM.06** will display a negative number.

Table 12.2 SM-SERCOS operating status codes

Pr MM.06	Status	Description
4	CP 4	Communication phase 4, full cyclic operation.
3	CP 3	Communication phase 3, cyclic operation.
2	CP 2	Communication phase 2, non-cyclic operation.
1	CP 1	Communication phase 1, slave identification sequence.
0	CP 0	Communication phase 0, checking network ring presence.
-1	Network error	No network present (or is in test mode).
-2	Initialisation failure	Module failed to initialise (or node address is zero).
-4	Module error	Error in the SM-SERCOS firmware.
-8	Re-booting	The drive interface is being initialised. This will be set for a prolonged period (up to 30s) whenever the drive database has to be re-written to the option module flash (e.g. after the drive firmware has changed).

NOTE

In system file versions prior to V01.02.00 it was possible to achieve CP4 with a trip present on the drive. Versions V01.02.00 and above will not allow the SERCOS network to reach CP4 with a trip present. The only exception to this is when a UU trip is present when SM-SERCOS initialises, this will not be reported as an error, however subsequent UU trips will be correctly reported. This allows the network to be started when powering up on 24V only.

12.7 Drive trip display codes

If the SM-SERCOS detects an error during operation, it will force a trip on the drive. However, the trip code displayed on the drive will only indicate which slot initiated the trip. The exact reason for the trip will be indicated in the SM-SERCOS error code parameter, Pr **MM.50**.

Table 12.3 shows the possible trip codes that will be displayed on the drive when a problem is detected with the SM-SERCOS or when the SM-SERCOS initiates a trip.

Table 12.3 Drive trip display codes

Trip Code	Fault	Description
SLx.HF	Hardware fault	The drive has detected that a Solutions Module is present, but is unable to communicate with it.
SLx.tO	Watchdog time-out	Not used by SM-SERCOS.
SLx.Er	Error	User trip generated by the SM-SERCOS
SLx.nF	Not installed	This trip will occur if a drive slot is configured for a SM-SERCOS, but a different module is installed in the slot.
SLx.dF	Different module installed	The slot configuration parameters stored in the drive are not valid SM-SERCOS configuration parameters. This trip will also occur when an SM-SERCOS is installed to a previously un-used slot.

12.8 SM-SERCOS network diagnostic parameters

SM-SERCOS network diagnostic destination		
Pr MM.14	Default	2025
	Range	
	Access	RW

The SERCOS MDT and AT can be written to a series of 32 bit parameters such as those in menu 20. Pr **MM.14** contains the starting parameter for the MDT data to start at, with each IDN using a single parameter (regardless of the size), after the MDT the AT is then stored in the next ascending parameter(s), again using 1 parameter per IDN.

SM-SERCOS network diagnostic enable		
Pr MM.13	Default	0
	Range	0 to 1
	Access	RW

To enable the recording of data from the SERCOS network, Pr **MM.13** must be set to 1, the transition of this parameter from 0 to 1 causes the value in Pr **MM.14** to be used as the starting parameter for data storage. Only the cyclic data from the MDT and AT are written (not the service channel, control and status words), only the part of the MDT corresponding to the SM-SERCOS address is written.

NOTE These diagnostic parameters must not be used for transferring data, they are provided for diagnostics only and must not be used as part of a control scheme.

NOTE If the value in Pr **MM.14** is changed, a transition of 0 to 1 is required on Pr **MM.13** for the change to become active.

12.9 SM-SERCOS error codes

SM-SERCOS error code		
Pr MM.50	Default	
	Range	0 to 255
	Access	RO

If the SM-SERCOS detects an error during operation, it will force a trip on the drive and update the error code parameter, (Pr **MM.50**). Table 12.4 shows the SM-SERCOS error codes.

Table 12.4 SM-SERCOS error codes

Error code	Fault	Description
0	No error detected	Indicates that the trip was not caused by the SM-SERCOS. It is possible to trip the drive externally via various communication channels.
54	Timer task over-run	Ensure that when homing the second encoder feedback is disabled in Pr MM.10 .
61	Configuration error	An invalid configuration has been detected.
65	Network loss	SM-SERCOS has detected a loss of communications from the master. Refer to Pr MM.07 .
70	FLASH transfer error	The SM-SERCOS was unable to upload the configuration parameters from its FLASH memory to the drive.

Table 12.4 SM-SERCOS error codes

Error code	Fault	Description
74	SM-SERCOS overtemperature	If the temperature inside the SM-SERCOS exceeds 82°C, the SM-SERCOS will trip the drive.
98	Internal watchdog error	Internal error. Cycle power to the drive to reset from this trip. If trip persists, replace the SM-SERCOS.
99	Internal software error	

12.10 SM-SERCOS serial number

SM-SERCOS serial number		
Pr MM.35	Default	
	Range	32-bit
	Access	RO

The serial number is loaded into the SM-SERCOS during manufacture and cannot be changed. It contains the last 7 digits of the 10-digit serial number from the Solutions Module label.

12.11 Diagnostic IDNs

The SERCOS master has the ability to read the SM-SERCOS diagnostic IDNs. These provide various status information about the drive and the SM-SERCOS, refer to each IDN for further details:

- Class 1 diagnostics “IDN - 00011” on page 37.
- Class 2 diagnostics “IDN - 00012” on page 38.
- Class 3 diagnostics “IDN - 00013” on page 38.
- Manufacturer class 1 diagnostics “IDN - 00129” on page 56.
- Manufacturer class 2 diagnostics “IDN - 00181” on page 61.
- Manufacturer class 3 diagnostics “IDN - 00182” on page 62.

13 Quick reference

13.1 SM-SERCOS parameter reference

Table 13.1 lists all the SM-SERCOS set-up parameters that are required to configure the module.

Table 13.1 SM-SERCOS parameter reference

Menu	Default	Cross reference	Description
Pr MM.01	409	Section 12.1 on page 99	Module ID code.
Pr MM.02		Section 12.2 on page 99	Major firmware version.
Pr MM.03	1	Section 12.3 on page 99	Node address.
Pr MM.04	3	Section 12.4 on page 100	Data rate.
Pr MM.05	4	Section 12.5 on page 100	Transmitter optical power level.
Pr MM.06		Section 12.6 on page 100	Operating status.
Pr MM.07	OFF (0)	Section 11.1 on page 87	Network loss trip.
Pr MM.08	ON (1)	Section 11.2 on page 87	Endian format.
Pr MM.09	ON (1)	Section 11.3 on page 88	Register control.
Pr MM.10	0	Section 11.4 on page 88	Second encoder enable.
Pr MM.11	0	Section 11.5 on page 88	Second encoder source.
Pr MM.12	0	Section 11.6 on page 89	Second encoder turn bits.
Pr MM.13	0	Section 12.8 on page 102	Network diagnostic enable.
Pr MM.14	0	Section 12.8 on page 102	Network diagnostic destination.
Pr MM.15	0	Section 11.7 on page 89	Homing backoff behavior.
Pr MM.16	0	Section 11.19 on page 97	Always require the IPOSYNC bit
Pr MM.17	1	Section 11.20 on page 97	Module timer task period
Pr MM.18	0		'Input' Data registers 8 - 9
Pr MM.19			

Table 13.1 SM-SERCOS parameter reference

Menu	Default	Cross reference	Description
Pr MM.20	0		'Output' Data registers 0 - 9
Pr MM.21			
Pr MM.22			
Pr MM.23			
Pr MM.24			
Pr MM.25			
Pr MM.26			
Pr MM.27			
Pr MM.28			
Pr MM.29			
Pr MM.30	0	Section 11.8 on page 89	Restore SM-SERCOS defaults.
Pr MM.31	0	Section 11.9 on page 90	Store to SM-SERCOS FLASH memory.
Pr MM.32	0	Section 5.4.9 on page 27	Re-initialise SM-SERCOS. This will automatically change back to 0 after re-initialisation.
Pr MM.33	0	Section 11.10 on page 90	Restore previous configuration from SM-SERCOS FLASH memory.
Pr MM.34	0	Section 11.11 on page 91	Marker pulse source selector.
Pr MM.35		Section 12.10 on page 103	Serial number.
Pr MM.36	0	Section 11.12 on page 92	Freeze main drive position.
Pr MM.37	0	Section 11.12 on page 92	Invert drive freeze.
Pr MM.38	0	Section 11.13 on page 92	Test mode.
Pr MM.39	0	Section 5.4.6 on page 25	Reverse on home switch.
Pr MM.40	0	Section 11.14 on page 92	Disable SM-SERCOS control.
Pr MM.41	1	Section 5.4.6 on page 25	Homing switch digital input source.
Pr MM.42	0	Section 5.4.7 on page 25	Position feedback source.
Pr MM.43	16	Section 5.4.8 on page 26	Encoder turn bits.
Pr MM.44		Section 10.2 on page 81	Synchronisation status.
Pr MM.45		Section 10.3 on page 81	Synchronisation period.
Pr MM.46	0	----	Reserved.
Pr MM.47			
Pr MM.48			
Pr MM.49			
Pr MM.50		Section 12.9 on page 102	SM-SERCOS error code.
Pr MM.51		Section 12.2 on page 99	Minor firmware version.

Safety Information
Introduction
Mechanical Installation
Electrical Installation
Getting started
IDNs
Manufacture IDNs
Control and Status Words
Procedure Commands
Data Synchronisation
Advanced Features
Diagnostics
Quick Reference
Glossary Of Terms
Index

13.2 SM-SERCOS IDN reference

Table 13.2 lists all the IDNs supported by SM-SERCOS.

Table 13.2 SM-SERCOS IDN reference

IDN	Default	Cross reference	Description
00001	1000	Section 6.3.1 on page 34	Control unit cycle time (t_{Ncyc}).
00002	1000	Section 6.3.2 on page 34	Communication cycle time (t_{Scyc}).
00003	90	Section 6.3.3 on page 34	Shortest AT transmission starting time ($t_{1.min}$).
00004	10	Section 6.3.4 on page 34	Transmit/receive time (t_{ATMT}).
00005	90	Section 6.3.5 on page 35	Minimum feedback processing time (t_5).
00006	90	Section 6.3.6 on page 35	AT transmission starting time (t_1).
00007	0	Section 6.3.7 on page 35	Feedback acquisition capture point (t_4).
00008	0	Section 6.3.8 on page 35	Command value valid time (t_3).
00009	1	Section 6.3.9 on page 36	Position of data record in MDT.
00010	4	Section 6.3.10 on page 36	Length of MDT.
00011		Section 6.3.11 on page 37	Class 1 diagnostics.
00012		Section 6.3.12 on page 38	Class 2 diagnostics.
00013		Section 6.3.9 on page 36	Class 3 diagnostics.
00014		Section 6.3.14 on page 39	Interface status.
00015	4	Section 6.3.15 on page 39	Telegram type.
00016		Section 6.3.16 on page 40	Configuration list of AT.
00017		Section 6.3.17 on page 40	IDN list of all operation data.
00018		Section 6.3.18 on page 40	IDN list of operational data in CP2.
00019		Section 6.3.19 on page 41	IDN list of operational data in CP3.
00021		Section 6.3.20 on page 41	IDN list of invalid operational data in CP2.
00022		Section 6.3.21 on page 41	IDN list of invalid operational data in CP3.
00024		Section 6.3.22 on page 41	Configuration list of MDT.
00025		Section 6.3.23 on page 42	IDN list of all procedure commands.
00028		Section 6.3.24 on page 42	MST error counter.

Table 13.2 SM-SERCOS IDN reference

IDN	Default	Cross reference	Description
00029		Section 6.3.25 on page 42	MDT error counter.
00030		Section 6.3.26 on page 42	Manufacturer version.
00032	3	Section 6.3.27 on page 43	Primary operation mode.
00033	3	Section 6.3.28 on page 43	Secondary operation mode.
00036	0	Section 6.3.29 on page 43	Velocity command value.
00037	0	Section 6.3.30 on page 43	Additive velocity command value.
00040		Section 6.3.31 on page 43	Velocity feedback value 1.
00041	4096	Section 6.3.32 on page 44	Homing velocity.
00042	65536	Section 6.3.33 on page 44	Homing acceleration.
00043	0	Section 6.3.34 on page 44	Velocity polarity parameter.
00044	0	Section 6.3.35 on page 45	Velocity data scaling type.
00045	1	Section 6.3.36 on page 45	Velocity data scaling factor.
00046	0	Section 6.3.37 on page 45	Velocity data scaling exponent.
00047	0	Section 6.3.38 on page 45	Position command value.
00051		Section 6.3.39 on page 46	Position feedback value.
00052	0	Section 6.3.40 on page 46	Reference distance 1.
00053		Section 6.3.41 on page 46	Position feedback value 2 (external feedback/ second encoder).
00055	0	Section 6.3.42 on page 47	Position polarity parameter.
00057	0	Section 6.3.43 on page 47	Position window.
00076	0	Section 6.3.44 on page 47	Position data scaling type.
00079		Section 6.3.45 on page 48	Rotational position resolution.
00080	0	Section 6.3.46 on page 48	Torque command value.
00081	0	Section 6.3.47 on page 48	Additive torque command value.
00084		Section 6.3.48 on page 48	Torque feedback value.
00085	0	Section 6.3.49 on page 49	Torque polarity parameter.

Safety Information
Introduction
Mechanical Installation
Electrical Installation
Getting started
IDNs
Manufacture IDNs
Control and Status Words
Procedure Commands
Data Synchronisation
Advanced Features
Diagnostics
Quick Reference
Glossary Of Terms
Index

Table 13.2 SM-SERCOS IDN reference

IDN	Default	Cross reference	Description
00086	0	Section 6.3.50 on page 49	Torque/force data scaling type.
00088	10	Section 6.3.51 on page 49	Receive to receive recovery time (t_{TMSTY}).
00089	0	Section 6.3.52 on page 49	MDT transmission starting time (t_2).
00090	10	Section 6.3.53 on page 50	Command value proceeding time (t_{MTSG}).
00091	3276800	Section 6.3.54 on page 50	Bipolar velocity limit value.
00092	10000	Section 6.3.55 on page 50	Bipolar torque limit value.
00095		Section 6.3.56 on page 51	Diagnostic message.
00096		Section 6.3.57 on page 51	Slave arrangement (SLKN).
00097	0	Section 6.3.58 on page 51	Mask class 2 diagnostics.
00098	0	Section 6.3.59 on page 52	Mask class 3 diagnostics.
00099		Section 6.3.60 on page 52	Reset class 1 diagnostics.
00100		Section 6.3.61 on page 52	Velocity loop proportional gain.
00101		Section 6.3.62 on page 52	Velocity loop integral gain.
00102		Section 6.3.63 on page 53	Velocity loop differential time.
00103	65536	Section 6.3.64 on page 53	Modulo value.
00104	2500	Section 6.3.65 on page 53	Position loop Kv-factor.
00106		Section 6.3.66 on page 53	Current loop proportional gain 1.
00107		Section 6.3.67 on page 53	Current loop integral gain 1.
00109		Section 6.3.68 on page 53	Motor peak current.
00110		Section 6.3.69 on page 54	Amplifier peak current.
00112		Section 6.3.70 on page 54	Amplifier rated current.
00114		Section 6.3.71 on page 54	Load limit of the motor.
00124	0	Section 6.3.72 on page 54	Standstill window.
00125	0	Section 6.3.73 on page 54	Velocity threshold.
00127		Section 6.3.74 on page 55	Communication 3 transition check.
00128		Section 6.3.75 on page 55	Communication 4 transition check.

Table 13.2 SM-SERCOS IDN reference

IDN	Default	Cross reference	Description
00129		Section 6.3.76 on page 56	Manufacturer class 1 diagnostics.
00130		Section 6.3.77 on page 56	Probe value 1 positive edge.
00131		Section 6.3.78 on page 56	Probe value 1 negative edge.
00132		Section 6.3.79 on page 57	Probe value 2 positive edge.
00133		Section 6.3.80 on page 57	Probe value 2 negative edge.
00134		Section 6.3.81 on page 57	MDT control word.
00135		Section 6.3.82 on page 57	AT status word.
00138	2147483647	Section 6.3.83 on page 57	Bipolar acceleration limit value.
00142		Section 6.3.84 on page 57	Application type.
00143		Section 6.3.85 on page 58	SERCOS interface version.
00147	260	Section 6.3.86 on page 58	Homing parameter.
00148		Section 6.3.87 on page 58	Drive controlled homing procedure.
00150	0	Section 6.3.88 on page 59	Reference offset 1.
00157	0	Section 6.3.89 on page 59	Velocity window.
00159	2147483647	Section 6.3.90 on page 59	Monitoring window.
00160	0	Section 6.3.91 on page 59	Acceleration data scaling type.
00161	1	Section 6.3.92 on page 59	Acceleration data scaling factor.
00162	0	Section 6.3.93 on page 59	Acceleration data scaling exponent.
00169	0	Section 6.3.94 on page 60	Probe control parameter.
00170		Section 6.3.95 on page 60	Probing cycle procedure command.
00172		Section 6.3.96 on page 60	Displacement to the referenced system procedure command.
00175	0	Section 6.3.97 on page 61	Displacement parameter 1.
00179		Section 6.3.98 on page 61	Probe status.
00181		Section 6.3.99 on page 61	Manufacturer class 2 diagnostics.
00182		Section 6.3.100 on page 62	Manufacturer class 3 diagnostics.
00185	10	Section 6.3.101 on page 62	Length of the configurable data record in the AT.

Safety Information
Introduction
Mechanical Installation
Electrical Installation
Getting started
IDNs
Manufacture IDNs
Control and Status Words
Procedure Commands
Data Synchronisation
Advanced Features
Diagnostics
Quick Reference
Glossary Of Terms
Index

Table 13.2 SM-SERCOS IDN reference

IDN	Default	Cross reference	Description
00186	10	Section 6.3.102 on page 62	Length of the configurable data record in the MDT.
00187		Section 6.3.103 on page 62	IDN list of configurable data in the AT.
00188		Section 6.3.104 on page 63	IDN list of configurable data in the MDT.
00189		Section 6.3.105 on page 63	Following distance.
00191		Section 6.3.106 on page 63	Cancel reference point procedure command.
00196		Section 6.3.107 on page 63	Motor rated current.
00206	0	Section 6.3.108 on page 64	Drive on delay time.
00207	0	Section 6.3.109 on page 64	Drive off delay time.
00208	0	Section 6.3.110 on page 64	Temperature data scaling type.
00292		Section 6.3.111 on page 64	List of supported operational modes.
00296	1000	Section 6.3.112 on page 65	Velocity feed forward gain.
00301	S-0-0000	Section 6.3.113 on page 65	Allocation of real-time control bit 1.
00303	S-0-0000	Section 6.3.114 on page 65	Allocation of real-time control bit 2.
00305	S-0-0000	Section 6.3.115 on page 66	Allocation of real-time status bit 1.
00307	S-0-0000	Section 6.3.116 on page 66	Allocation of real-time status bit 2.
00376		Section 6.3.117 on page 67	Baud rate.
00380		Section 6.3.118 on page 67	DC bus voltage.
00384		Section 6.3.119 on page 67	Amplifier temperature.
00390		Section 6.3.120 on page 67	Diagnostic number.
00393	2	Section 6.3.121 on page 68	Command value mode.
00400	0	Section 6.3.122 on page 68	Home switch.
00403		Section 6.3.123 on page 69	Position feedback value status.
00404	0	Section 6.3.124 on page 69	Position command value status
00405	0	Section 6.3.125 on page 69	Probe 1 enable.
00406	0	Section 6.3.126 on page 69	Probe 2 enable.
00409		Section 6.3.127 on page 69	Probe 1 positive latched.

Table 13.2 SM-SERCOS IDN reference

IDN	Default	Cross reference	Description
00410		Section 6.3.128 on page 70	Probe 1 negative latched.
00411		Section 6.3.129 on page 70	Probe 2 positive latched.
00412		Section 6.3.130 on page 70	Probe 2 negative latched.
42001		Section 11.18 on page 94	Application menu 3 read-write integer (Pr 20.01).
42002		Section 11.18 on page 94	Application menu 3 read-write integer (Pr 20.02).
42003		Section 11.18 on page 94	Application menu 3 read-write integer (Pr 20.03).
42004		Section 11.18 on page 94	Application menu 3 read-write integer (Pr 20.04).
42021		Section 11.18 on page 94	Application menu 3 read-write long integer (Pr 20.21).
42022		Section 11.18 on page 94	Application menu 3 read-write long integer (Pr 20.22).
42023		Section 11.18 on page 94	Application menu 3 read-write long integer (Pr 20.23).
42024		Section 11.18 on page 94	Application menu 3 read-write long integer (Pr 20.24).

Safety Information
Introduction
Mechanical Installation
Electrical Installation
Getting started
IDNs
Manufacture IDNs
Control and Status Words
Procedure Commands
Data Synchronisation
Advanced Features
Diagnostics
Quick reference
Glossary Of Terms
Index

14 Glossary Of Terms

Address: This is the unique network identification given to a networked device to allow communication on a network. When a device sends or receives data the address is used to determine the source and the destination of the message.

Amplifier: Traditional name for a servo variable speed drive slave axis.

Amplifier Telegram: Slave response message (containing its cyclic and non-cyclic data) to the master

AT: See Amplifier Telegram

Bit: A binary digit, this may have the value of 1 or 0.

Byte: A collection of 8 binary digits that collectively store a value. This may be signed or unsigned.

Casting: The process of changing between data sizes without changing the value represented, e.g. changing from 16-bit to 32-bit.

Control word: A collection of binary digits that are used to control the drive. Features typically include directional controls, run controls and other similar functions.

Communication phase: This reflects the status of the network and is graded 0 to 4.

Cyclic data: This consists of values that are sent at regular or cyclic intervals across the network. A typical use of cyclic data would be the transmission of a speed reference or a control word.

Data format: Determines the quantity and function of the data sent and received across the network.

Data rate: Determines the communication speed of the network, the higher the value the more data can be sent across the network in the same time period.

Device: A piece of equipment connected to a network, this may be any type of equipment including repeaters, hubs, masters or slaves.

Direct data mapping: Data is sent directly to the mapping parameters in the drive rather than the parameters redirecting the data to another parameter.

Double word: A 32 bit word, this may be signed or unsigned.

Grounding: See earthing.

Earthing: Describes the electrical safety or shielding connections for the module.

Endian format: When a value uses more than 8 bits to represent its value it needs to be sent in sets of 8 bits (bytes) across the network, the endian format determines the order the bytes that constitute the whole value are transmitted.

Event task: A special way to use a message or change of state to trigger a software routine.

Freeze: A function where motor position data is captured and stored following event.

IDN: Identification number.

Long word: A 32bit data word that may be signed or unsigned.

Network cycle time: Is the periodic rate at which data is sent and received on the network.

Network loss trip: A method to determine when a node has lost communication with the master.

Node: A device on the network. This may be either a device such as a drive or part of the network such as a repeater.

Non-cyclic data: Data that is requested or sent by the master as required. This is not sent on a regular basis and generally allows access to any parameter. This is useful for occasional changes or configuration purposes.

Marker pulse: Signal produced by a motor feedback device once per shaft revolution.

Master: The controlling device on the network, generally this will include programming features.

Master Data Telegram (MDT): Messages (containing its cyclic and non-cyclic data) sent to the slave devices.

Master Synchronisation Telegram (MST): This telegram is transmitted from the master on a predefined time basis and is used to keep the slave devices synchronised with the master.

Re-initialise: Restarts the module using any configured settings.

SERCOS: SErial Real time COmmunication System interface.

Service channel: See non-cyclic data

Slave: A device on the SERCOS network such as a drive or sensor. A slave device will only respond to messages from a master.

Status word: A value that denotes the status of the drive. Each bit within the word will have a specific meaning.

Synchronisation: A method of ensuring that devices use data simultaneously.

Telegram: A message used within data communication. This term is sometimes used to represent a generic message on the network.

Watchdog: A method used to determine if a communication system is ok. A typical watchdog scheme uses a handshaking system to check both the master and slave are participating in communications.

Word: A collection of 16 binary digits.

Index

A	
Always require IPOSYNC bit	97
Auxiliary	13
Auxiliary supply	13
B	
Backup	90
Backup supply	13
Byte order	87
C	
Cable	16
Cautions	6
Certificate	13
Compliance	7
Conformance	13
Control word	73
Control word bit functions	74
Cyclic data	71
D	
Data endian format	87
Data rate	100
Data rates	23, 25, 100
Diagnostic flow chart	98
Diagnostics	98
Disable SM-SERCOS control	92
D-Type pin out	15
Dual SM-Applications	72
E	
Electrical installation	15
Electrical safety	6
Endian format	87
Environmental limits	7
Error codes	102
F	
Firmware version	99
G	
Getting started	19
Glossary of terms	112
H	
Hardware enable	73
Homing backoff behaviour	89
I	
ID code	99
IDNs	33

Safety Information
Introduction
Mechanical Installation
Electrical Installation
Getting started
IDNs
Manufacture IDNs
Control and Status Words
Procedure Commands
Data Synchronisation
Advanced Features
Diagnostics
Quick reference
Glossary Of Terms
Index

L	
Local solutions access	93
M	
Menu 60	93
Module timer task period	97
N	
Network length	17
Network loss trip	87
Node address	99
Non-cyclic data	76
O	
Operating status	27, 100
Operating status codes	27, 101
P	
Parameter reference	104
Parameters - adjusting	7
Problems	98
Q	
Quick reference	104
R	
Re-initialise	27
Restore configuration	90
Restore defaults	89
S	
Safety Information	6
Safety of personnel	6
Saving	28
Second encoder enable	88
Second encoder source	88
Second encoder turns bits	89
SECURE DISABLE	6
Serial number	103
Set-up flow chart	22
Single SM-Applications	72
Specification	11
Status codes	27, 101
Status word	75
Storing parameters	90
T	
Terminal descriptions	15
Trip 54	88
Trip display codes	101
U	
Unidrive SP control word	73
W	
Warnings	6
Word order	87

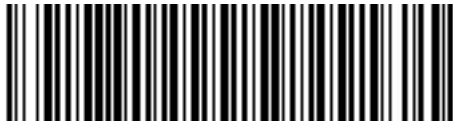

0471-0048-06